

REVISIONS			
REV.	DESCRIPTION	DATE	APPROVED
01	ORIGINAL	02/03/2012	B.S.A

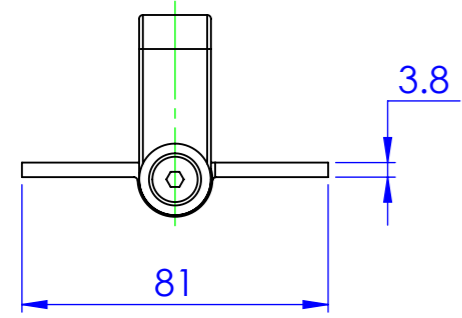

ITEM NO.	PART NUMBER	DESCRIPTION	QTY.
1	04482.44	FACADE MID-HINGE PIN	1
2	05102.01	FACADE HINGE FLAP	2
3	05005.01	HINGE SLEEVE (PLASTIC)	4
4	03029.152	WASHER NO.2 (FACADE)	1
5	03029.151	WASHER NO.1 (FACADE)	2
6	HANDLE	HINGE HANDLE	1
7	03014.44	M6 x 12 SKT CSK SCREW	2
8	03029.144	COUNTERSUNK WASHER	2

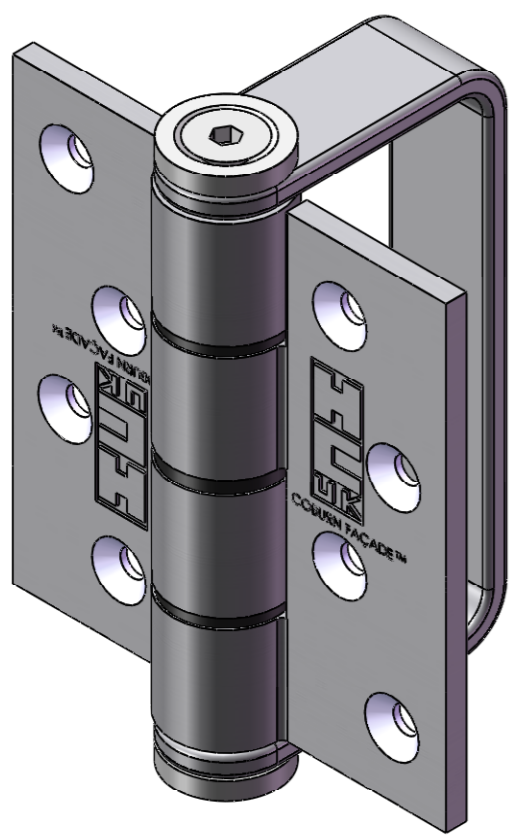

**COBURN**  
SLIDING SYSTEMS

HILLALDAM COBURN LTD  
UNIT 16, MERTON INDUSTRIAL PARK  
LEE ROAD, LONDON  
SW19 3HX,  
UK  
TEL:+44 (0)20 8545 6680 FAX:+44 (0)20 8545 6723  
E-Mail:sales@hillaldam.co.uk  
Web:www.coburn.co.uk  
© COPYRIGHT HILLALDAM COBURN LTD

THE INFORMATION CONTAINED IN THIS DRAWING IS THE SOLE PROPERTY OF <HILLALDAM COBURN LTD>. ANY REPRODUCTION IN PART OR AS A WHOLE WITHOUT THE WRITTEN PERMISSION OF <HILLALDAM COBURN LTD> IS PROHIBITED.

MATERIAL  
SEE COMPONENT DRAWINGS

FINISH  
SEE COMPONENT DRAWINGS

UNLESS OTHERWISE SPECIFIED:

**DIMENSION(mm) TOLERANCE**  
ZERO PL DECIMAL ±0.2  
ONE PL DECIMAL ±0.1  
TWO PL DECIMAL ±0.05

ANGULAR TOLERANCE ±0.5°

FORGING TOLERANCE SEE BS 4114

COMMENTS: REMOVE ALL SHARP EDGES AND BURRS

DRAWN DATE  
BRYAN.S.A 02/03/2012

CHECKED DATE  
02/03/2012

DIMENSIONS ARE IN mm  
DO NOT SCALE DRAWING

FILE DRG. No.  
3/ 00000/ 000

TITLE:  
**FAÇADE INTERMEDIATE HINGE HANDLE (SS)**

SIZE DRG/PART. No. REV  
A3 09766.01 01

SCALE: NTS WEIGHT: SHEET: 1/1