

ITEM NO.	PART NUMBER	DESCRIPTION	QTY.
1	04525.11	BOLT HOUSING EXTRUSION	1
2	04529.11	FLUSH BOLT PLATE 150	1
3	04525.02	SHOOT EXTR. (04526.11)	1

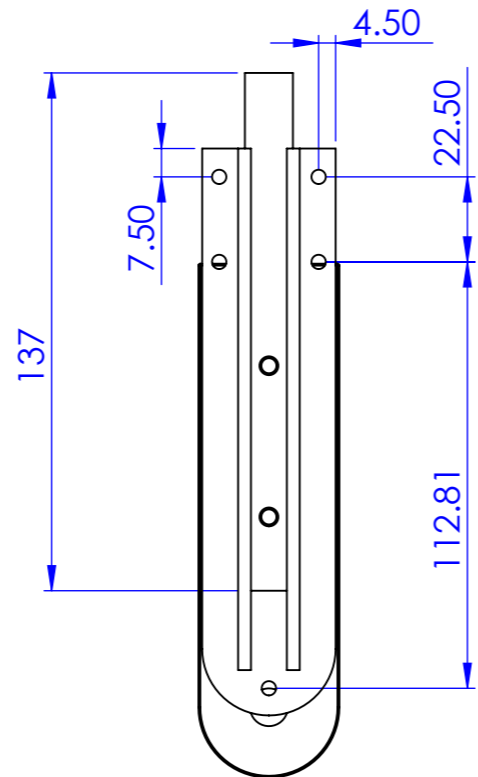

BODY SLOT DETAIL
PT. NO. 04525.11

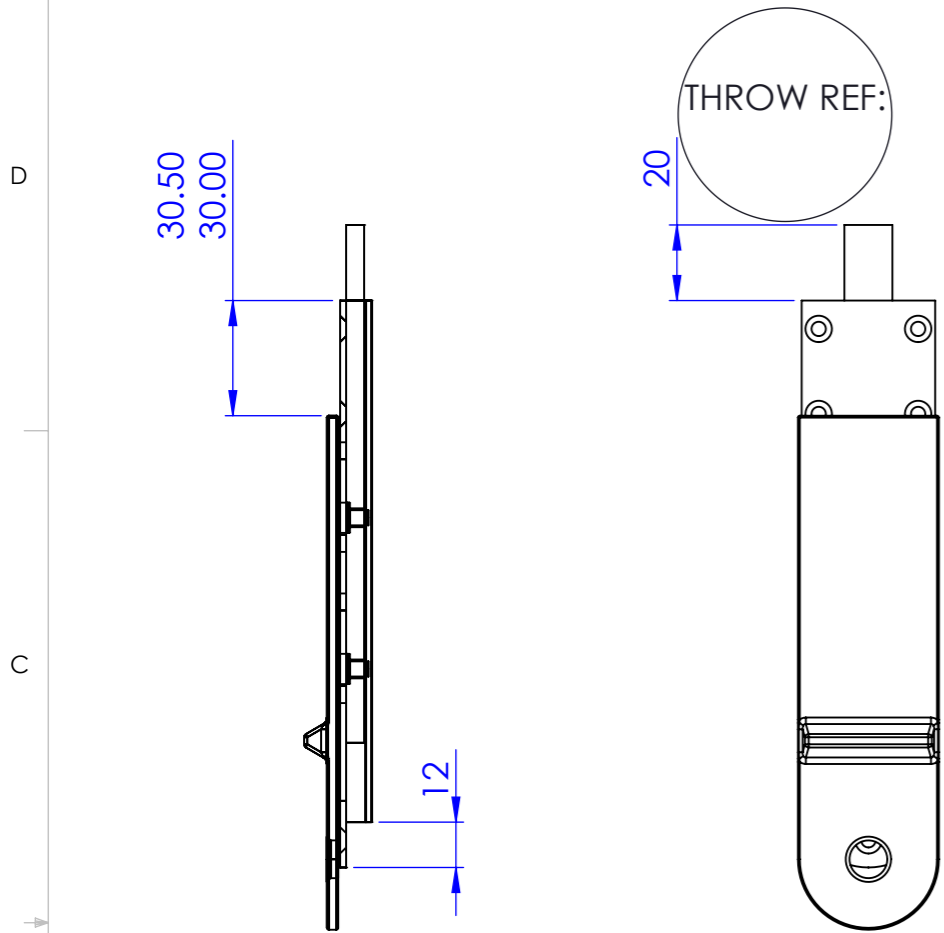
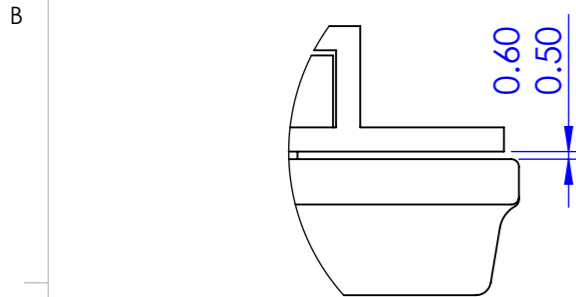
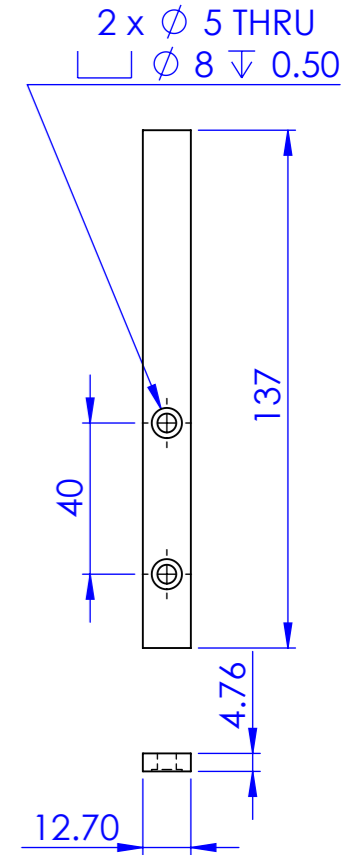
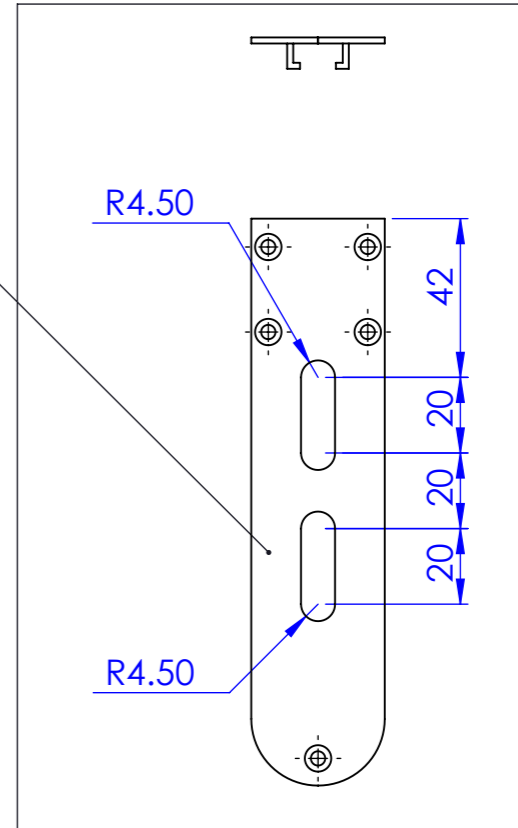

DETAIL A
SCALE 2 : 1



THE INFORMATION CONTAINED IN THIS DRAWING IS THE SOLE PROPERTY OF <HILLDAM COBURN>. ANY REPRODUCTION IN PART OR AS A WHOLE WITHOUT THE WRITTEN PERMISSION OF <HILLDAM COBURN> IS PROHIBITED.

ISSUE	MOD NO.	USED ON	UNLESS OTHERWISE SPECIFIED:	NAME	DATE
01		13/05/96	DIMENSIONS ARE IN INCHES TOLERANCES: FRACTIONAL ± ANGULAR: MACH ± BEND ± TWO PLACE DECIMAL ± THREE PLACE DECIMAL ±	DRAWN E.JOHNSON	31/01/07
02			INTERPRET GEOMETRIC TOLERANCING PER:	CHECKED ISSUE	ISSUE
03			MATERIAL SEE INDIVIDUAL PARTS	ENG APPR. E.JOHNSON	31/01/07
04			FINISH SILVER POWDER COAT	MFG APPR. F.DENNIS	31/01/07
05			DO NOT SCALE DRAWING	Q.A. E.JOHNSON	31/01/07
06				COMMENTS:	

ISSUE		
TITLE: FLUSH BOLT 150		
SIZE A3	DWG. NO. 95695.01	REV 01
SCALE: 1:2	WEIGHT:	SHEET 1 OF 1