

Scale 1:2

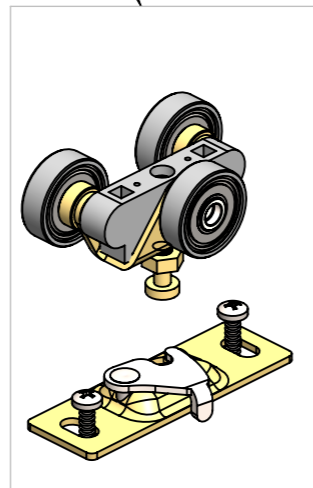
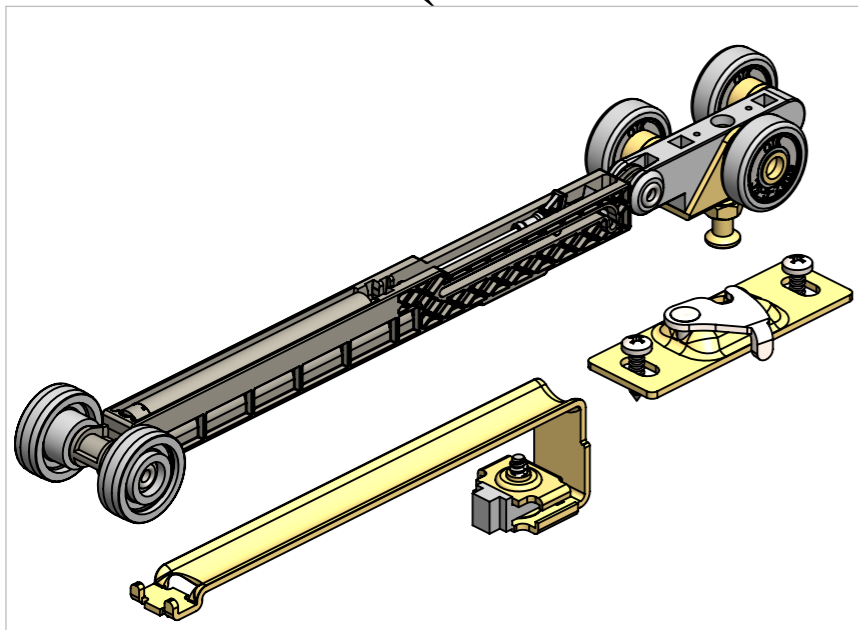
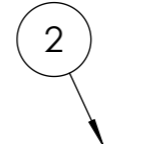
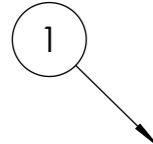
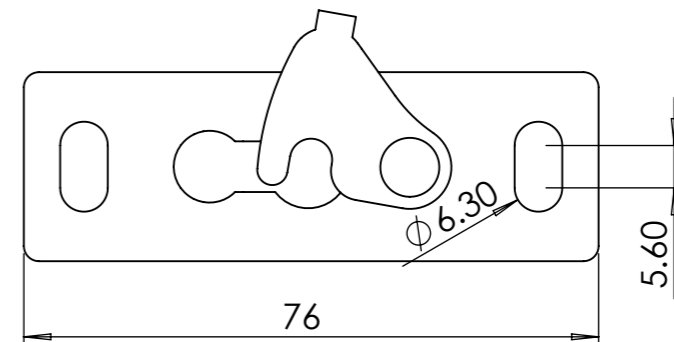
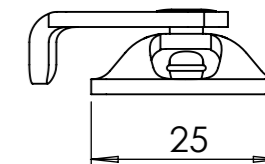
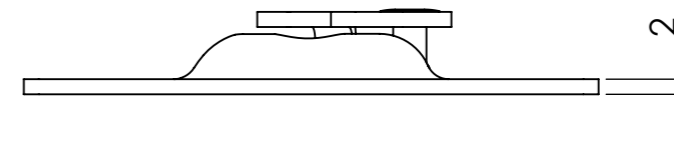
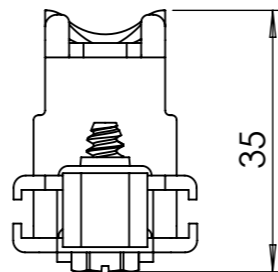
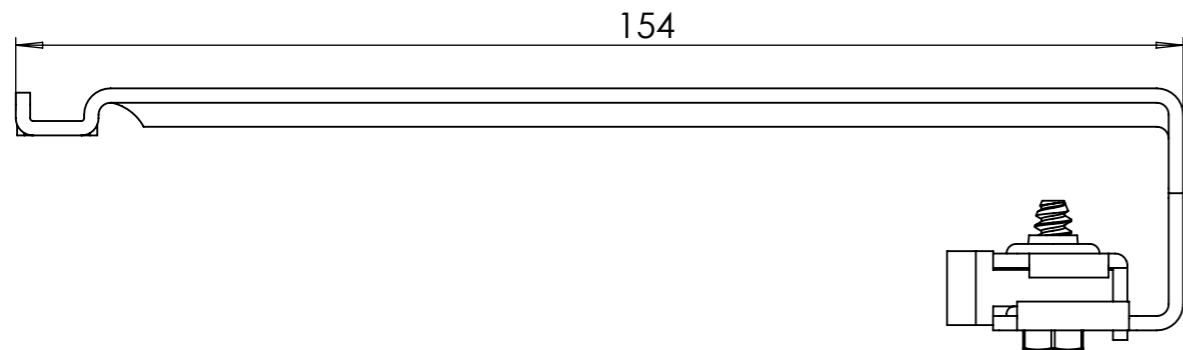
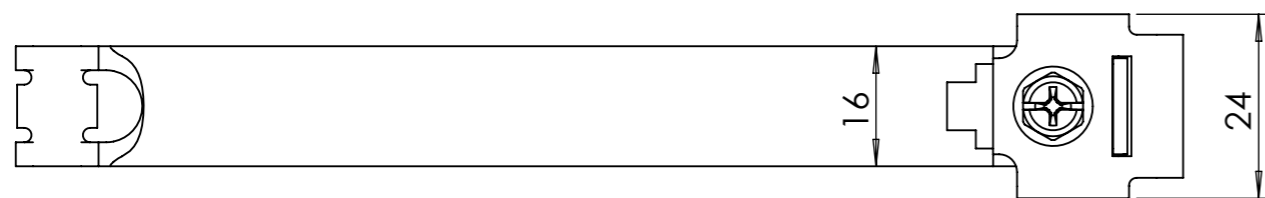
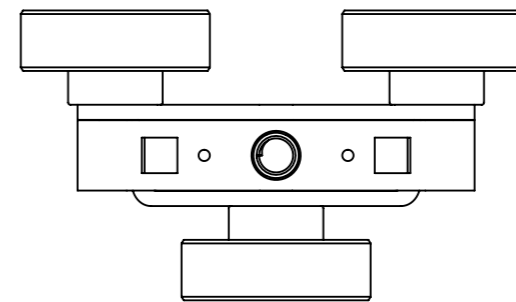
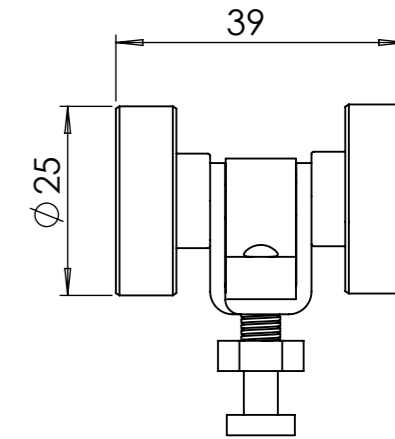
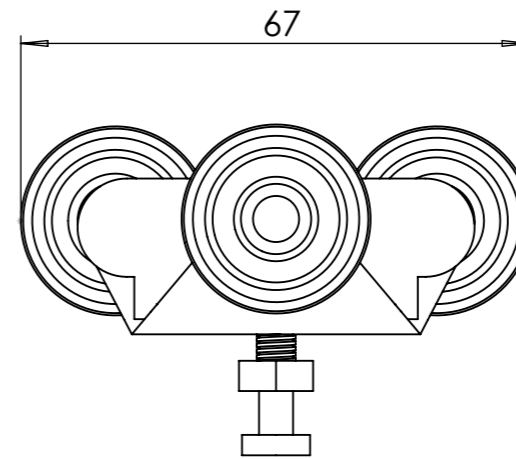
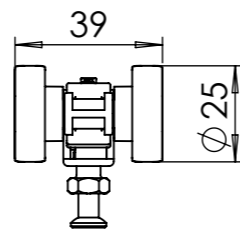

Scale 1:2

ITEM NO.	PART NUMBER	DESCRIPTION	QTY.
1	30636.01	HIDEAWAY CONCEALED SOFT CLOSER - Rev.01	1
2	61607.01	HIDEAWAY HANGER HEAVY DUTY - Rev.01	1
3	06426.40	HIDEAWAY - CONCEALED SOFT CLOSER - FITTING INSTRUCTION	1

COBURN SLIDING SYSTEMS LIMITED

Unit 1, Cardinal west,
Godmanchester, PE29 2XN
United Kingdom

TEL: +44 (0)20 8545 6680
FAX: +44 (0)20 8545 6720
E-Mail: sales@coburn.co.uk
Web: www.coburn.co.uk

© COPYRIGHT COBURN SLIDING SYSTEMS LIMITED
THE INFORMATION CONTAINED IN THIS DRAWING IS THE
SOLE PROPERTY OF «COBURN SLIDING SYSTEMS LIMITED». ANY
REPRODUCTION IN PART OR AS A WHOLE WITHOUT THE WRITTEN
PERMISSION OF «COBURN SLIDING SYSTEMS LIMITED» IS PROHIBITED.

UNLESS OTHERWISE SPECIFIED:

DIMENSION(mm) TOLERANCE
ZERO PL DECIMAL ±0.2
ONE PL DECIMAL ±0.1
TWO PL DECIMAL ±0.05

ANGULAR
TOLERANCE ±0.5°

FORGING TOLERANCE SEE
BS EN 10243

ALL EDGES WILL BE ROUNDED
WITH 0.2mm

COMMENTS: IF IN DOUBT ASK!

MATERIAL

FINISH



FIRST ANGLE
PROJECTION

DRAWN by:
Adrian BOGDAN

DATE:
20/07/2017

CHECKED by:

DATE:

SIZE
A3

DRAWING TYPE

Final part drawing

TITLE:

HIDEAWAY
CONCEALED SOFT
CLOSER KIT
H30 AND H36

DWG NO.

30642

REV.

01

SCALE: 1:1

WEIGHT:

SHEET 1 / 1