

## Quality Assurance

We are committed to the highest standards of excellence

Constant testing to the latest BS EN ISO 9001 Standards ensures that quality is maintained and a programme of product improvement is regularly reviewed and updated.

Below are some of our current accreditations and trade associations memberships.



Sliding & Folding Door Systems 

External Door Systems  
(Corrosion Resistant) 

Glass Door Systems 

Wardrobe Sliding Door Systems 

# PRODUCT CATALOGUE

Architectural Sliding Door Systems

For further information on our products and services:  
Tel: +44 (0)20 8545 6680  
sales@coburn.co.uk  
www.coburn.co.uk

Coburn Sliding Systems Limited  
Unit 1 Cardinal West  
Cardinal Way  
Cardinal Distribution Park  
Godmanchester  
Huntingdon  
Cambridgeshire  
PE29 2XN  
United Kingdom



CAT Issue March 2024



# Product Contents

Coburn architectural sliding and folding door hardware systems

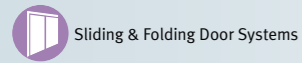

## Sliding & Folding Door Systems

# 6-47

- 8-9 • Hideaway
- 10-11 • Easyslide
- 12-13 • Straightaway 50
- 14-15 • Straightaway 100
- 16-17 • Straightaway 130
- 18-19 • Straightaway 180
- 20-21 • Straightaway 250
- 22-23 • Straightaway 600
- 24-25 • Microline
- 26-27 • Straightaway Telescopic
- 28-29 • Flat Track Mini
- 30-31 • Flat Track Range
- 32-33 • Vetroslide Timber
- 34-35 • Trackless
- 36-37 • Duo Swing
- 38-39 • Folding 180
- 40-41 • Foldaside 30
- 42-43 • Foldaside 50
- 44-45 • Foldaside 75
- 46-47 • Foldaside 150

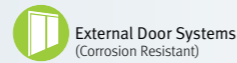

## External Door Systems

# 48-59

- 50-53 • Dreamfold
- 54-55 • Eternal 130
- 56-57 • Eternal 180
- 58-59 • Eternal 250

# Product Contents

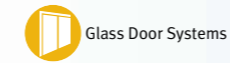

## Glass Sliding & Folding Door Systems

# 60-73

- 62-63 • Slyde 15 Glass
- 64-65 • Straightaway G80
- 66-67 • Straightaway G130
- 68-69 • Flexiglas 50
- 70-71 • Flexiglas 120
- 72-73 • Vetroslide Glass
- 74-75 • Crystalline EF60
- 76-77 • Crystalline CF60

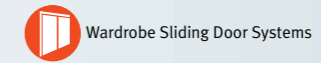

## Wardrobe Sliding Door Systems

# 78-93

- 80-81 • Flushslide
- 82-83 • Slyde 15 Timber
- 84-85 • Slyde 50
- 86-87 • Celantur 50
- 88-89 • Topslide 50
- 90-91 • Celantur 80
- 92-93 • Celantur Folding

# Door System Specifier



| Product   | Max Door Weight (kgs) | Max Door Height | Door/Glass Thickness | Soft Closing | Track Dims (W x H) |
|---|-----------------------|-----------------|----------------------|--------------|--------------------|
| <b>SLIDING &amp; FOLDING DOOR SYSTEMS</b>       |                       |                 |                      |              |                    |
| Hideaway  | 90                    | 2743mm          | 25-50mm              | Optional     | 89mm x 60mm        |
| Easyslide                                       | 100                   | 2040mm          | 30-40mm              | Optional     | 45mm x 40mm        |
| Straightaway 50                                 | 50                    | 2100mm          | 20-50mm              | Optional     | 27mm x 25mm        |
| Straightaway 100                                | 100                   | 2700mm          | 20-50mm              | Optional     | 31mm x 38mm        |
| Straightaway 130                                | 130                   | 3000mm          | 20-50mm              | Optional     | 38mm x 41mm        |
| Straightaway 180                                | 180                   | 3500mm          | 25-55mm              | Optional*    | 48mm x 47mm        |
| Straightaway 250                                | 250                   | 4000mm          | 25-55mm              | Optional*    | 51mm x 55mm        |
| Straightaway 600                                | 600                   | 6000mm          | 30-65mm              | N/A          | 70mm-78mm          |
| Microline                                       | 250                   | 4000mm          | 30-55mm              | Optional     | Variable           |
| Straightaway Telescopic                         | 250                   | 4000mm          | 30-55mm              | Optional     | Variable           |
| Flat Track Mini                                 | 50                    | 2700mm          | 25-38mm              | Optional     | 4mm-25mm           |
| Flat Track Range                                | 360                   | 4000mm          | 35-75mm              | Optional     | Variable           |
| Vetroslide                                      | 100                   | 3000mm          | 35-45mm              | Standard     | Dia 25mm           |
| Trackless                                       | 50                    | 2450mm          | 40-50mm              | N/A          | 16mm-60mm          |
| Duoswing  | 70                    | 1981mm          | 35-50mm              | Optional     | 45mm x 40mm        |
| Folding 180                                     | 25                    | 3000mm          | 40-44mm              | N/A          | N/A                |
| Foldaside 30                                    | 30                    | 2500mm          | 20-40mm              | N/A          | 27mm x 24.5mm      |
| Foldaside 50                                    | 50                    | 3000mm          | 30-50mm              | N/A          | 48mm x 47mm        |
| Foldaside 75                                    | 75                    | 3000mm          | 35-50mm              | N/A          | 51mm x 55mm        |
| Foldaside 150                                   | 150                   | 4500mm          | 42-65mm              | N/A          | 70mm-78mm          |
| <b>EXTERNAL DOOR SYSTEMS</b>                    |                       |                 |                      |              |                    |
| Dreamfold                                       | 85                    | 3300mm          | 35-70mm              | N/A          | 51mm x 55mm        |
| Eternal 130                                     | 130                   | 3000mm          | 20-50mm              | Optional     | 38mm x 41mm        |
| Eternal 180                                     | 180                   | 3500mm          | 25-55mm              | Optional*    | 48mm x 47mm        |
| Eternal 250                                     | 250                   | 4000mm          | 25-55mm              | Optional*    | 51mm x 55mm        |
| <b>GLASS SLIDING &amp; FOLDING DOOR SYSTEMS</b> |                       |                 |                      |              |                    |
| Slyde 15  | 15                    | 1200mm          | 5mm                  | Standard     | Variable           |
| Straightaway G80                                | 80                    | 2400mm          | 8/10mm               | Optional     | 31mm x 38mm        |
| Straightaway G130                               | 130                   | 3000mm          | 10/12mm              | Optional     | 38mm x 41mm        |
| Flexiglas 50                                    | 50                    | 2400mm          | 8/10mm               | Optional     | 52mm x 58mm        |
| Flexiglas 120                                   | 120                   | 2700mm          | 8/10mm               | Optional     | 52mm x 58mm        |
| Vetroslide                                      | 100                   | 3000mm          | 8-12mm               | N/A          | Dia 25mm           |
| Crystalline Folding EF60                        | 60                    | 2500mm          | 10/12mm              | N/A          | 45mm x 42mm        |
| Crystalline Folding CF60                        | 60                    | 2500mm          | 10/12mm              | N/A          | 45mm x 42mm        |
| <b>WARDROBE SLIDING DOOR SYSTEMS</b>            |                       |                 |                      |              |                    |
| Flushslide                                      | 85                    | 3000mm          | 20-45mm              | Standard     | 295mm x 39mm       |
| Slyde 15  | 15                    | 1200mm          | 16-19mm              | Standard     | Variable           |
| Slyde 50  | 50                    | 2700mm          | 14-45mm              | Standard     | 18mm x 14mm        |
| Celantur 50                                     | 50                    | 2700mm          | 14-20mm              | Standard     | 73mm x 14mm        |
| Topslide 50                                     | 50                    | 2700mm          | 18-25mm              | Standard     | 36.5mm x 52mm      |
| Celantur 80                                     | 80                    | 3000mm          | 16-46mm              | Standard     | 71mm x 14mm        |
| Celantur Folding                                | 20                    | 3000mm          | >= 16mm              | Standard     | 56mm x 28mm        |

\*Track dimension for soft closer: 53mm (w) x 64mm (h)

This catalogue is only intended for use by authorized distributors and customers of Coburn Sliding Systems Ltd. All contents of this catalogue are the property of Coburn Sliding Systems Ltd. All technical data, drawings, illustrations and dimensions are intended for informational purposes only. Coburn Sliding Systems Ltd cannot accept any liability for printing errors or mistakes and reserve the right to make alterations, changes and design amendments without notification. Re-printing of this catalogue or extracts thereof are strictly forbidden unless authorised in writing by Coburn Sliding Systems Ltd.

# What's New



## Straightaway 600

Page 22/23

Straightaway 600 is a high calibre, heavy duty top hung system. maximum door weight of 600kg.



## Flat Track Mini

Page 28/29

Flat Track Mini is a lighter version of the Coburn Flat Track range. It offers a traditional rustic look for doors up to 50kg.



## Vetroslide Timber

Page 32/33

Vetroslide Timber sliding hardware offers contemporary look for doors up to 100 kg.

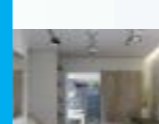

## Trackless

Page 34/35

Coburn Trackless is a totally hidden hardware system for internal sliding timber doors.



## Folding 180

Page 38/39

Folding 180 uses rototranslating door technology to allow doors to fold back 180 degrees allowing the panels to sit flat against the return wall when in the open position.



## Foldaside 150

Page 46/47

Foldaside 150 is a sophisticated high quality hardware system designed for internal or external folding doors up to 150 kg per leaf.



## Slyde 15 Glass

Page 62/63

Slyde 15 system provides a highly functional solution for bookcases, display units and cabinet doors.

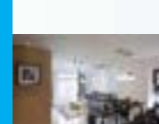

## Vetroslide Glass

Page 72/73

Vetroslide Glass sliding hardware offers contemporary look for doors up to 100 kg.



## Slyde 15 Timber

Page 82/83

Slyde 15 system provides a highly functional solution for bookcases, display units and cabinet doors.



## Slyde 50

Page 84/85

Slyde 50 is a space saving solution for sliding wardrobe and cupboard doors. Suitable for wide range of door thicknesses.



## Topslide 50

Page 88/89

Topslide 50 is a neat and stylish wardrobe sliding system, perfectly suited for light to medium weight wardrobe doors.

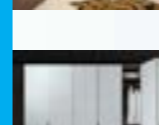

## Celantur Folding

Page 92/93

Celantur Folding wardrobe is a stylish wardrobe system combining function with performance. The system is suited for light weight folding doors.







This versatile and durable range of sliding and folding doors are the ideal choice for residential and commercial applications.

# Sliding & Folding Door Systems







## Hideaway Sliding & Folding Door Systems

### Door Specifications

- Maximum Door Weight: 90kg
- Door Thickness: 25-44mm up to 50mm with cavity widening kit (61613)
- Maximum Door Height: 2743mm
- Track Dimensions: 89mm (w) x 60mm (h)

### Hardware Specifications

- Steel studs, screwed to pre-assembled header provide maximum rigidity
- Keyhole slots in aluminium track allow easy removal in unlikely event of this being necessary
- Unique hanger locking clip allows easy fitting and removal of the door from hanger if required
- Flush pull handles and other accessories also available
- Simultaneous opening (synchro) optional
- Concealed soft closing available for doors over 610mm wide
- Concealed soft closing and soft opening available for doors over 715mm wide

# Hideaway Pocket Door Systems

## Product Overview

Hideaway is a sliding door framing kit suitable for plasterboard walls, created to hide sliding doors within a wall cavity. Hideaway is able to recover the space normally occupied by traditional hinged doors and is a simple but perfect solution for lightweight sliding pocket doors.

### NOTE:

- All accessories to be ordered separately
- For more detailed information please refer to our Technical Data Sheet available on request

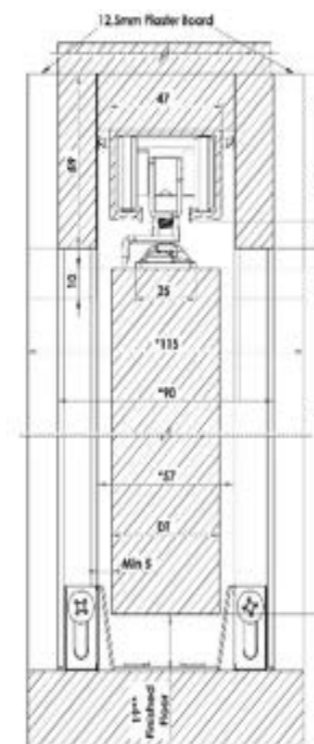
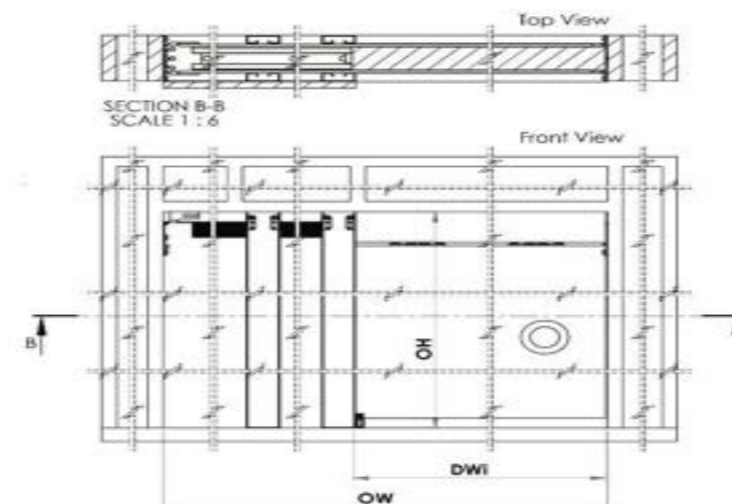

\*\*Allows for carpets + underlay

Maximum door weight 90kg  
 DH - Door height, maximum 2743mm  
 DWi - Door width, maximum 1524mm  
 DT - Door thickness,  
 Minimum 25mm with standard bracket  
 Maximum 44mm with standard bracket  
 Maximum 50mm with cavity widening kit  
 OW - Opening width  
 OH - Opening height

### NOTE:

For doors over 44mm thick  
 61613 widening kit MUST be used.

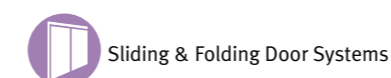

For further information please contact us:  
 Tel: +44 (0)20 8545 6680 sales@coburn.co.uk www.coburn.co.uk

## Hideaway Pocket Door Kits (Excluding Jamb Kit)

| Article No. | Description   | Image |
|-------------|---|-------|
| 61730       | H30, to suit door size 762 x 2040mm                   |       |
| 61736       | H36, to suit door size 915 x 2040mm                   |       |
| 61742       | H42, to suit door size 1067 x 2040mm                  |       |
| 61842       | H42A, to suit door size 1067 x 2743mm                 |       |
| 61848       | H48A, to suit door size 1219 x 2743mm                 |       |
| 61854       | H54, to suit door size 1371 x 2743mm                  |       |
| 61860       | H60A, to suit door size 1524 x 2743mm                 |       |
| Article No. | Description   | Image |
| 30636       | Concealed softcloser for H42, H42A, H54 and H60A kits |       |
| 30642       | Concealed softcloser for H30 and H36 kits             |       |
| 30701       | Self closer   |       |
| 61405       | Simultaneous synchro kit for doors up to 1200mm wide  |       |
| 61600       | Hideaway connector                                    |       |
| 61613       | Hideaway cavity widening kit (up to 50mm thick doors) |       |
| 61604       | Hideaway hanger, 56kgs                                |       |
| 61607       | Hideaway hanger, 90kgs                                |       |
| 61700       | Hideaway component kit (For H30 and H36 only)         |       |
| 61615       | Hideaway plywood reinforcement bracket                |       |
| 61911       | Concealed guide                                       |       |
| 95604       | Pocket door hold open piston                          |       |





# Easyslide

## Pocket Door Systems

### Product Overview

Easyslide is a high quality and innovative pocket door system for use with plasterboard walls where the door is required to silently slide within a cavity wall. The system is supplied in kit form and is designed to be easily and quickly fitted to drastically reduce on-site installation time.

**NOTE:**

- All accessories to be ordered separately
- For more detailed information please refer to our Technical Data Sheet available on request

| Article No. | Description                                       | Image |
|-------------|---|-------|
| 30629       | Soft closer, single damper, 120kgs (Door mounted) |       |
| 30701       | Self closer (up to 100kg)                         |       |
| 62916       | Jamb kit 100mm finished wall (Tanganika)          |       |
| 95604       | Pocket door piston                                |       |

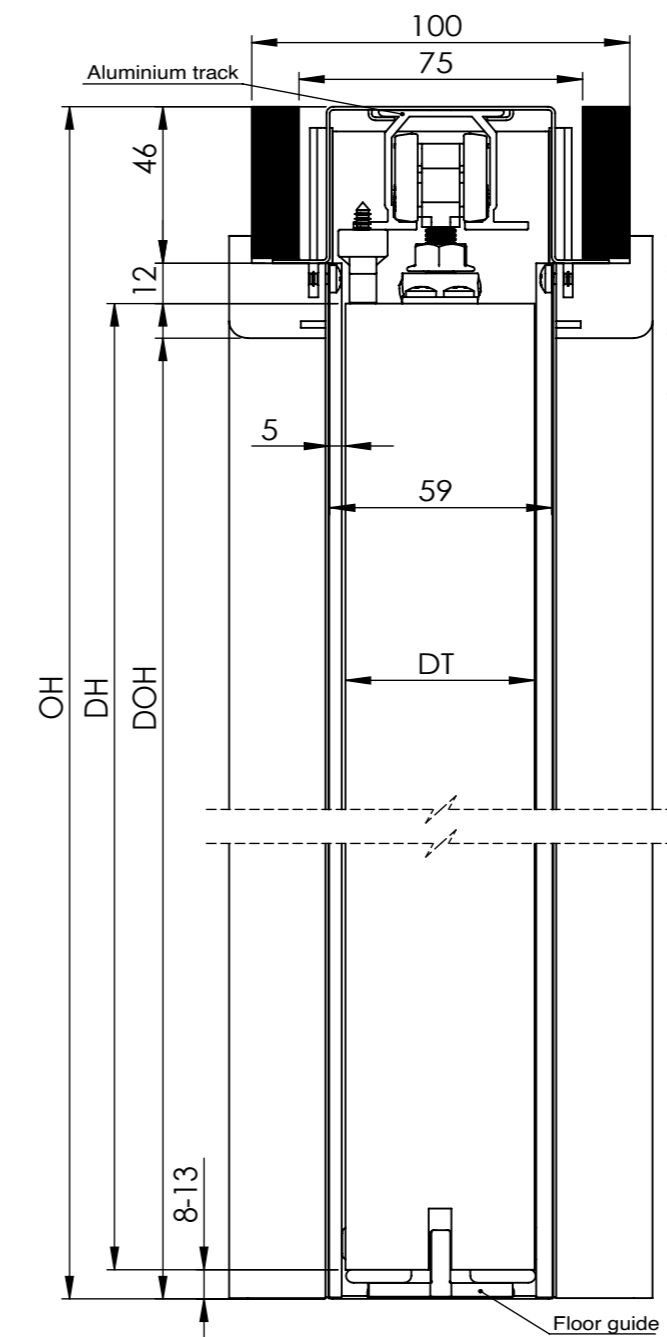

OW - Opening width  
 OH - Opening height  
 DOW - Recommended usable door opening width  
 DOH - Recommended usable door opening height

| Part No. | DW x DH     | DOW  | DOH  | OW   | OH   |
|----------|-------------|------|------|------|------|
| 62851    | 610 x 1981  | 595  | 1971 | 1315 | 2061 |
| 62852    | 686 x 1981  | 626  | 1971 | 1462 | 2061 |
| 62853    | 762 x 1981  | 747  | 1971 | 1617 | 2061 |
| 62854    | 838 x 1981  | 800  | 1971 | 1720 | 2061 |
| 62855    | 914 x 1981  | 884  | 1971 | 1940 | 2061 |
| 62856    | 626 x 2040  | 600  | 2030 | 1330 | 2110 |
| 62857    | 726 x 2040  | 700  | 2030 | 1540 | 2120 |
| 62858    | 826 x 2040  | 800  | 2030 | 1740 | 2120 |
| 62859    | 926 x 2040  | 900  | 2030 | 1940 | 2120 |
| 62860    | 1026 x 2040 | 1000 | 2030 | 2140 | 2120 |

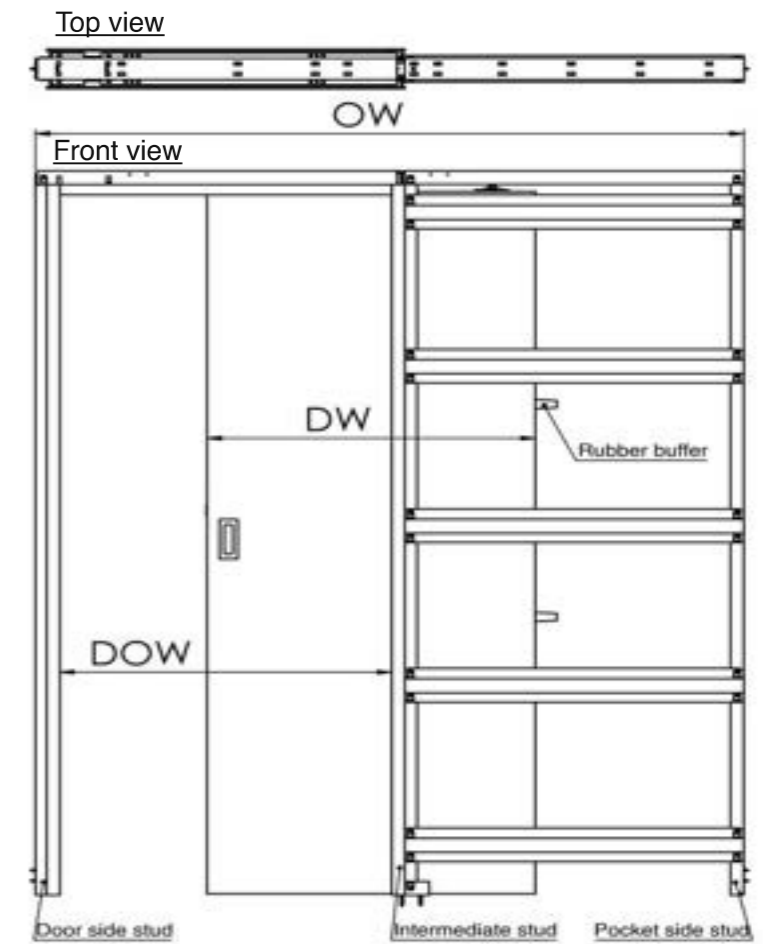

### Easyslide Pocket Door Systems



#### Door Specifications

- Maximum Door Weight: 100kg
- Door Thickness: 30-40mm
- Maximum Door Height: 2040mm (standard)
- Track Dimensions: 45mm (w) x 40mm (h)

#### Hardware Specifications

- Horizontal and vertical profiles manufactured from galvanised steel to provide maximum rigidity.
- Click and Snapfitting - No tools required
- No floor channels required
- Available in many sizes
- Jamb kits available to suit 100mm finished wall sizes
- Jamb kits supplied in Tanganika finish

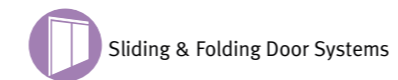



Straightaway 50 Sliding & Folding Door Systems

# Straightaway 50

## Sliding Door Systems

### Product Overview

Straightaway 50 is a reliable and versatile solution for internal timber doors and is ideal for room dividers and wardrobe doors. The aluminium track and nylon wheeled hangers ensure smooth, quiet, trouble free operation whilst the detachable doors plates enable easy and efficient installation. The compact profile of the track, top fixing hangers and floor mounted guides ensure Straightaway 50 is unobtrusive and allows you to achieve a clear threshold. Track(s) can be face fixed in single runs using brackets or in single or multiple runs to the underside of the lintel. This coupled with the wide range of accessories available makes Straightaway 50 flexible enough to perform in numerous applications.

#### NOTE:

- All accessories to be ordered separately
- For more detailed information please refer to our Technical Data Sheet available on request

#### STRAIGHTAWAY 50

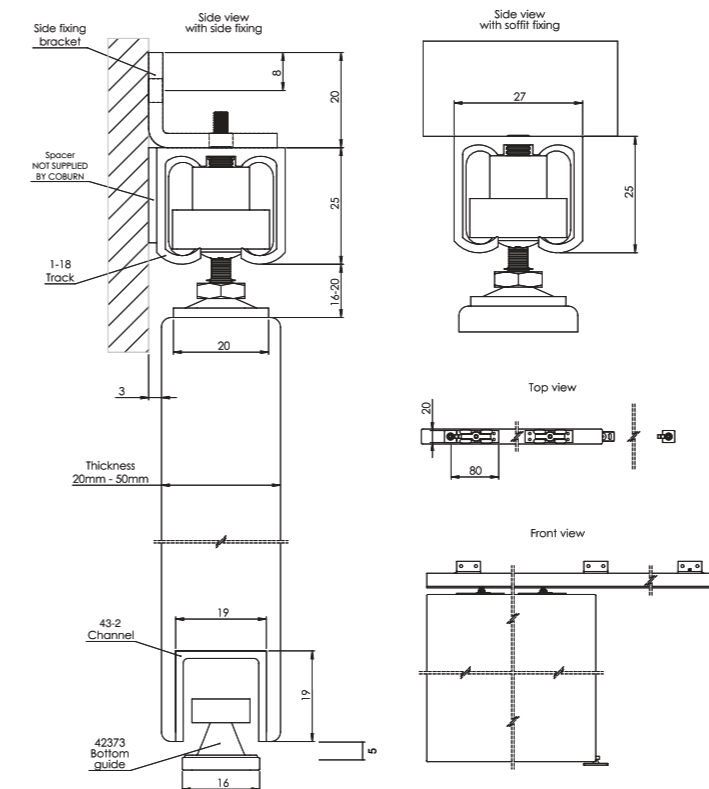

| Article No. | Finish/Size  | Bottom Channel |
|-------------|--|----------------|
| 43220       | Mill Finish, 15x15mm, 2000mm                         |                |
| 43224       | Mill Finish, 15x15mm, 2400mm                         |                |
| 43230       | Mill Finish, 15x15mm, 3000mm                         |                |
| 43236       | Mill Finish, 15x15mm, 3600mm                         |                |
| 43240       | Mill Finish, 15x15mm, 4000mm                         |                |
| 43260       | Mill Finish, 15x15mm, 6000mm                         |                |
| Article No. | Finish/Size  | Track          |
| 11812       | Anodised Aluminium, 1200mm                           |                |
| 11818       | Anodised Aluminium, 1800mm                           |                |
| 11824       | Anodised Aluminium, 2400mm                           |                |
| 11850       | Anodised Aluminium, 5000mm                           |                |
| Article No. | Description  | Image          |
| 01818       | Trackset for one door up to 900mm                    |                |
| 01824       | Trackset for one door up to 1200mm                   |                |
| 01050       | Straightaway 50 hanger pack                          |                |
| 01030       | Face fixed bracket set (3 pcs)                       |                |
| 01040       | Face fixed bracket set (4 pcs)                       |                |
| 01005       | Face fixed bracket set (5 pcs)                       |                |
| 01008       | Face fixed bracket set (8 pcs)                       |                |
| 42373       | Nylon wheel roller guide (pair)                      |                |
| 44354       | Adjustable wall mounted guide                        |                |
| 61405       | Simultaneous synchro kit for doors up to 1200mm wide |                |
| 30701       | Self-Closer  |                |

### Door Specifications

- Maximum Door Weight: 50kg
- Door Thickness: 20-50mm
- Maximum Door Height: 2100mm
- Door Construction:  
Internal timber doors only
- Track Dimensions: 27mm (w) x 25mm (h)

### Hardware Specifications

- Tracks can be ceiling mounted or face fixed
- Synchronised simultaneous opening optional
- Self-Closing optional
- No recessed floor tracks required







## Straightaway 100 Sliding & Folding Door Systems

### Product Overview

Straightaway 100 has been designed to offer the Customer a range of options and features that provide alternative solutions for residential and lightweight commercial applications. The system which is predominantly suitable for interior doors is highly durable due to its nylon bodied hanger.

#### NOTE:

- All accessories to be ordered separately
- For more detailed information please refer to our Technical Data Sheet available on request

### Door Specifications

- Maximum Door Weight: 100kg
- Door Thickness: 20-50mm
- Maximum Door Height: 2700mm
- Door Construction: Internal/external metal or timber doors
- Track Dimensions: 31mm (w) x 38mm (h)

### Hardware Specifications

- Tracks can be ceiling mounted or face fixed
- Soft closing mechanism concealed within the track
- Synchronised simultaneous opening optional
- Self-Closing optional
- No recessed floor tracks required for timber doors
- Soft closing and soft opening with single damper available for doors 900mm wide and over.
- Soft closing and soft opening with double damper available for doors 620mm wide and over.

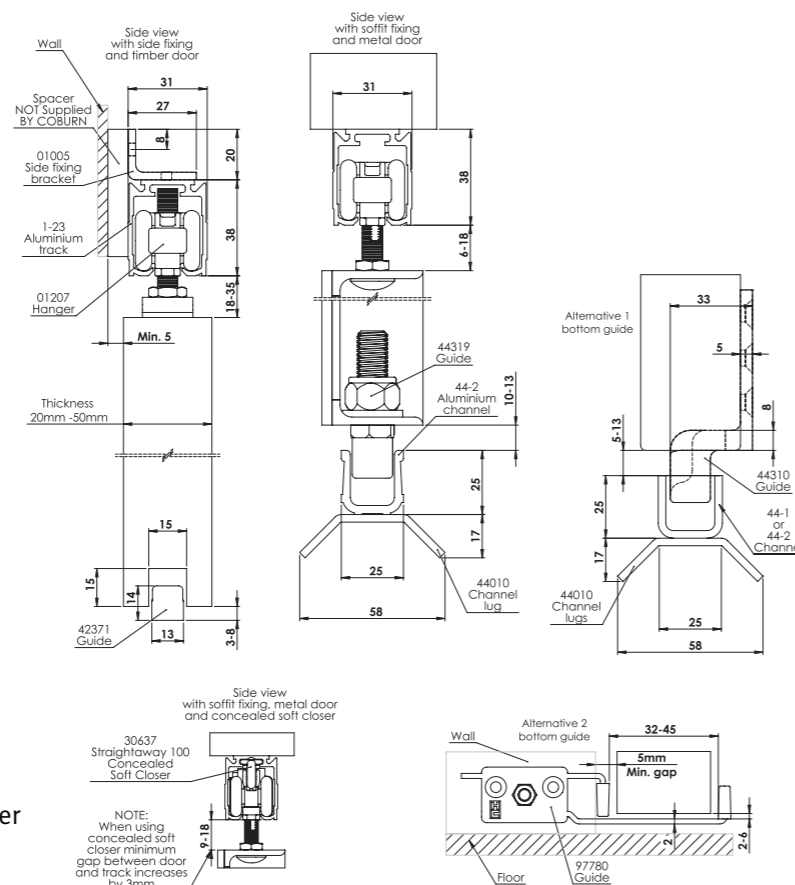

# Straightaway 100 Sliding Door Systems

| Article No. | Description  | Image |
|-------------|--|-------|
| 01030       | Face fixed bracket set (3 pcs)                                 |       |
| 01040       | Face fixed bracket set (4 pcs)                                 |       |
| 01005       | Face fixed bracket set (5 pcs)                                 |       |
| 01008       | Face fixed bracket set (8 pcs)                                 |       |
| 01105       | Aluminium side fixing bracket for use with 1-12 track          |       |
| 01725       | Track stop, pair   |       |
| 01007       | Closed end piece for use with 1-12 track (Used with 01105 bkt) |       |
| 30637       | Soft closer, single damper, 100kgs (mounted in track)          |       |
| 30701       | Self-Closer  |       |
| 61405       | Simultaneous synchro kit for doors up to 1200mm wide           |       |
| 97741       | Microline  |       |
| 97791       | Telescopic 2 Door  |       |
| 97792       | Telescopic 3 Door  |       |
| 44354       | Adjustable wall mounted guide                                  |       |
| 30664       | Soft closer, double damper, 100kgs (mounted in track)          |       |

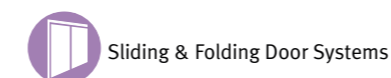
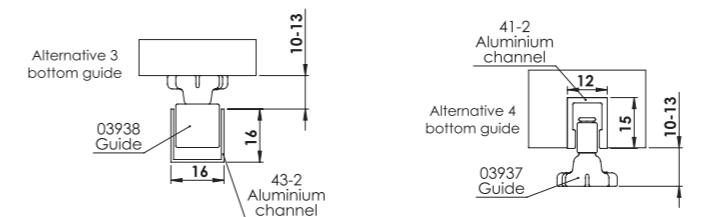

For further information please contact us:  
Tel: +44 (0)20 8545 6680 sales@coburn.co.uk www.coburn.co.uk



| Article No. | Finish/Size  | Bottom Channel |
|-------------|--|----------------|
| 41215       | Mill Finish, 12x15mm, 1500mm                                     |                |
| 41218       | Mill Finish, 12x15mm, 1800mm                                     |                |
| 41221       | Mill Finish, 12x15mm, 2100mm                                     |                |
| 41224       | Mill Finish, 12x15mm, 2400mm                                     |                |
| 41230       | Mill Finish, 12x15mm, 3000mm                                     |                |
| 41236       | Mill Finish, 12x15mm, 3600mm                                     |                |
| 41260       | Mill Finish, 12x15mm, 6000mm                                     |                |
| 43220       | Mill Finish, 15x15mm, 2000mm                                     |                |
| 43224       | Mill Finish, 15x15mm, 2400mm                                     |                |
| 43230       | Mill Finish, 15x15mm, 3000mm                                     |                |
| 43236       | Mill Finish, 15x15mm, 3600mm                                     |                |
| 43240       | Mill Finish, 15x15mm, 4000mm                                     |                |
| 43260       | Mill Finish, 15x15mm, 6000mm                                     |                |
| 44215       | Mill Finish, 25x25mm, 1500mm                                     |                |
| 44218       | Mill Finish, 25x25mm, 1800mm                                     |                |
| 44221       | Mill Finish, 25x25mm, 2100mm                                     |                |
| 44224       | Mill Finish, 25x25mm, 2400mm                                     |                |
| 44230       | Mill Finish, 25x25mm, 3000mm                                     |                |
| 44236       | Mill Finish, 25x25mm, 3600mm                                     |                |
| 44260       | Mill Finish, 25x25mm, 6000mm                                     |                |
| Article No. | Finish/Size  | Track          |
| 12320       | Anodised Aluminium, 2000mm                                       |                |
| 12324       | Anodised Aluminium, 2400mm                                       |                |
| 12330       | Anodised Aluminium, 3000mm                                       |                |
| 12336       | Anodised Aluminium, 3600mm                                       |                |
| 12340       | Anodised Aluminium, 4000mm                                       |                |
| 12360       | Anodised Aluminium, 6000mm                                       |                |
| 11215       | Galvanised Steel, 1500mm   |                |
| 11218       | Galvanised Steel, 1800mm   |                |
| 11221       | Galvanised Steel, 2100mm   |                |
| 11224       | Galvanised Steel, 2400mm   |                |
| 11230       | Galvanised Steel, 3000mm   |                |
| 11240       | Galvanised Steel, 4000mm   |                |
| 11250       | Galvanised Steel, 5000mm   |                |
| 11260       | Galvanised Steel, 6000mm   |                |
| Article No. | Description  | Image          |
| 01218       | Trackset for one door up to 950mm                                |                |
| 01224       | Trackset for one door up to 1200mm                               |                |
| 01207       | 100 hanger with concealed apron plate for timber and metal doors |                |
| 03937       | Adjustable rattle proof guide – 6mm roller                       |                |
| 03938       | Adjustable rattle proof guide – 13mm roller                      |                |
| 44310       | Cast iron plough guide, pair, (35/44mm timber doors)             |                |
| 44319       | Floor guide, pair, (metal doors)                                 |                |
| 97780       | Jamb fixed adjustable guide                                      |                |



Straightaway 130 Sliding & Folding Door Systems

### Door Specifications

- Maximum Door Weight: 130kg
- Door Thickness: 20-50mm
- Maximum Door Height: 3000mm
- Track Dimensions: 38mm (w) x 41mm (h)

### Hardware Specifications

- Tracks can be ceiling mounted or face fixed.
- Soft closing mechanism concealed within the track is available.
- Track is self-cleaning due to the angled nylon wheels on the door hanger.
- No recessed floor tracks required for timber doors.
- Soft closer available for doors 680mm wide and over.
- Soft closing and soft opening with single damper on each end available for doors 1020mm wide and over.
- Soft closing and soft opening with double damper available for doors 615mm wide and over.



# Straightaway 130 Sliding Door Systems

## Product Overview

Straightaway 130 is a quiet and dependable system designed for interior and exterior sliding doors up to 130kg per leaf and is ideally suited for use in residential and commercial applications. The system is effortless to operate and extremely durable, due to its nylon bodied hangers complete with four angled nylon outer wheels and precision bearings all housed in a compact aluminium track.

### NOTE:

- All accessories to be ordered separately
- For more detailed information please refer to our Technical Data Sheet available on request

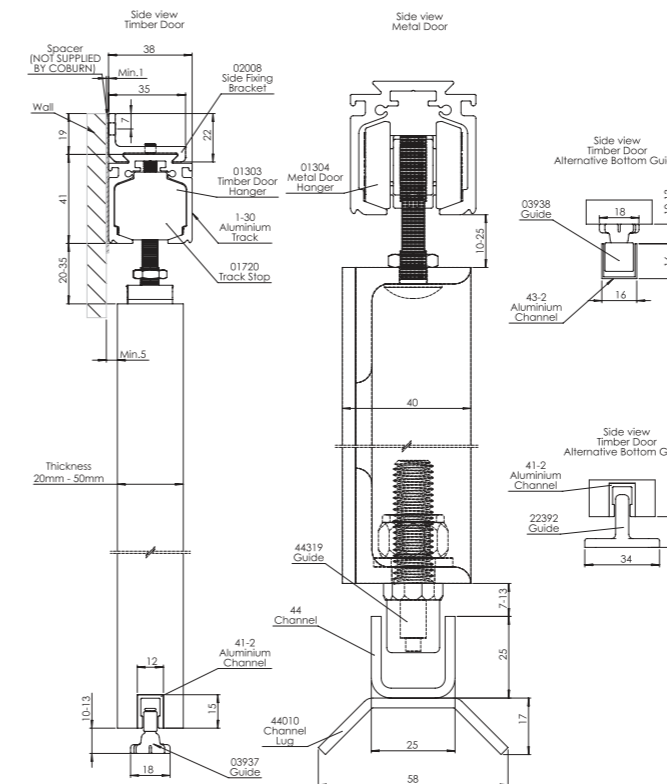

| Article No. | Finish/Size                  | Bottom Channel |
|-------------|------------------------------|----------------|
| 41224       | Mill Finish, 12x15mm, 2400mm |                |
| 41236       | Mill Finish, 12x15mm, 3600mm |                |
| 41260       | Mill Finish, 12x15mm, 6000mm |                |
| 43220       | Mill Finish, 15x15mm, 2000mm |                |
| 43224       | Mill Finish, 15x15mm, 2400mm |                |
| 43230       | Mill Finish, 15x15mm, 3000mm |                |
| 43236       | Mill Finish, 15x15mm, 3600mm |                |
| 43240       | Mill Finish, 15x15mm, 4000mm |                |
| 43260       | Mill Finish, 15x15mm, 6000mm |                |
| 44224       | Mill Finish, 25x25mm, 2400mm |                |
| 44236       | Mill Finish, 25x25mm, 3600mm |                |
| 44260       | Mill Finish, 25x25mm, 6000mm |                |

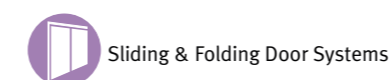

For further information please contact us:  
Tel: +44 (0)20 8545 6680 sales@coburn.co.uk www.coburn.co.uk

| Article No. | Finish/Size  | Track |
|-------------|--|-------|
| 13020       | Anodised Aluminium, 2000mm                                     |       |
| 13024       | Anodised Aluminium, 2400mm                                     |       |
| 13030       | Anodised Aluminium, 3000mm                                     |       |
| 13036       | Anodised Aluminium, 3600mm                                     |       |
| 13040       | Anodised Aluminium, 4000mm                                     |       |
| 13060       | Anodised Aluminium, 6000mm                                     |       |
| Article No. | Description  | Image |
| 01303       | 130 hanger with concealed apron plate for timber doors, (pair) |       |
| 01304       | 130 hanger for metal doors, (pair)                             |       |
| 03937       | Adjustable rattle proof guide - 6mm roller                     |       |
| 03938       | Adjustable rattle proof guide - 13mm roller                    |       |
| 22392       | Floor guide, plastic, (timber doors)                           |       |
| 44319       | Floor guide, pair, (metal doors)                               |       |
| 02008       | Face fixed bracket set (5 pcs)                                 |       |
| 02009       | Face fixed bracket set (8 pcs)                                 |       |
| 02010       | Joining bracket  |       |
| 01720       | Track stop, (pair)   |       |
| 30614       | Soft closer, single damper, 130kgs (mounted in track)          |       |
| 44354       | Adjustable wall mounted guide                                  |       |
| 97741       | Microline  |       |
| 97791       | Telescopic 2 Door  |       |
| 97792       | Telescopic 3 Door  |       |
| 30661       | Soft closer, double damper, 130kgs (mounted in track)          |       |





Straightaway 180 Sliding & Folding Door Systems

# Straightaway 180 Sliding Door Systems

## Product Overview

Straightaway 180 is a sophisticated and versatile top hung system designed for medium to heavy duty sliding doors up to 180kg. The system can easily accommodate sliding doors in a variety of architectural openings and is supplied with four wheeled hangers incorporating nylon coated wheels and precision ball bearings.

### NOTE:

- All accessories to be ordered separately
- For more detailed information please refer to our Technical Data Sheet available on request

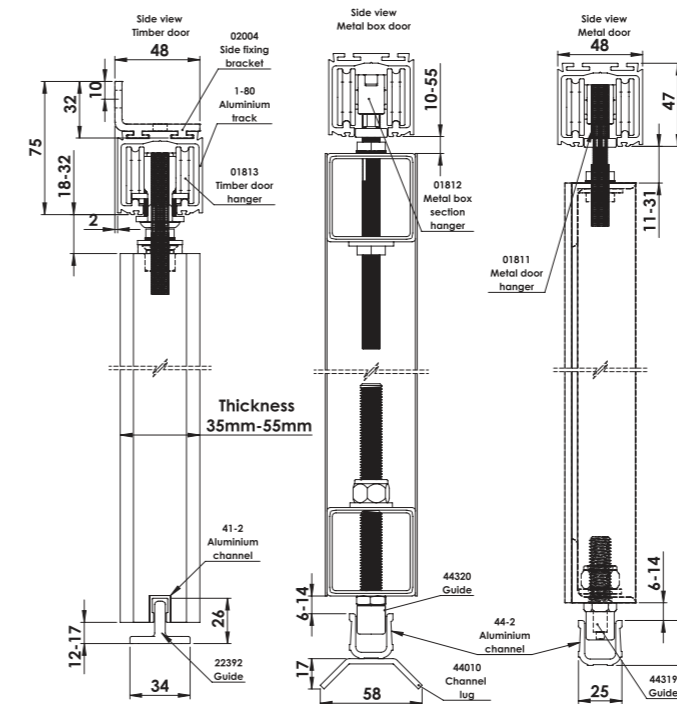

| Article No. | Finish/Size                  | Bottom Channel |
|-------------|------------------------------|----------------|
| 41224       | Mill Finish, 12x15mm, 2400mm |                |
| 41236       | Mill Finish, 12x15mm, 3600mm |                |
| 41260       | Mill Finish, 12x15mm, 6000mm |                |
| 44224       | Mill Finish, 25x25mm, 2400mm |                |
| 44236       | Mill Finish, 25x25mm, 3600mm |                |
| 44260       | Mill Finish, 25x25mm, 6000mm |                |

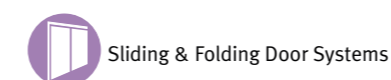

For further information please contact us:  
Tel: +44 (0)20 8545 6680 sales@coburn.co.uk www.coburn.co.uk



| Article No. | Finish/Size   | Track |
|-------------|---|-------|
| 18024       | Anodised Aluminium, 2400mm                                    |       |
| 18030       | Anodised Aluminium, 3000mm                                    |       |
| 18036       | Anodised Aluminium, 3600mm                                    |       |
| 18040       | Anodised Aluminium, 4000mm                                    |       |
| 18060       | Anodised Aluminium, 6000mm                                    |       |
| 25924       | Anodised Aluminium, 2400mm                                    |       |
| 25930       | Anodised Aluminium, 3000mm                                    |       |
| 25936       | Anodised Aluminium, 3600mm                                    |       |
| 25960       | Anodised Aluminium, 6000mm                                    |       |
|             |   |       |
| Article No. | Description   | Image |
| 01811       | 180 hanger for metal doors (pair)                             |       |
| 01812       | 180 hanger for box frame metal doors (pair)                   |       |
| 01813       | 180 hanger with concealed apron plate for timber doors (pair) |       |
| 44319       | Floor guide, pair, (metal doors)                              |       |
| 44320       | Extended floor guide (metal box frame doors)                  |       |
| 22392       | Nylon floor guide (timber doors)                              |       |
| 02718       | Track stop, (pair)  |       |
| 02005       | Face fixed bracket set (5 pcs)                                |       |
| 02006       | Face fixed bracket set (8 pcs)                                |       |
| 97741       | Microline   |       |
| 97791       | Telescopic 2 Door   |       |
| 97792       | Telescopic 3 Door   |       |
| 30638       | Soft closer 180 kg (concealed in track)                       |       |
| 44354       | Adjustable wall mounted guide                                 |       |

## Door Specifications

- Maximum Door Weight: 180kg
- Door Thickness: 25-55mm
- Maximum Door Height: 3500mm
- Track Dimensions: 48mm (w) x 47mm (h)
- Track Dimensions for 25-9 track (soft closer) 53mm (w) x 64mm (h)

## Hardware Specifications

- Tracks can be ceiling mounted or face fixed
- Hangers manufactured with zinc cast solid bodies and delrin nylon outer wheels complete with precision ball bearings to ensure smooth and silent operation
- Variable height adjustment on doors
- Fittings available for timber, aluminium or metal doors
- Soft closing available for doors 800mm wide and over.
- Soft closing and soft opening available for doors 1230mm wide and over.





Straightaway 250 Sliding & Folding Door Systems

# Straightaway 250 Sliding Door Systems

## Product Overview

Straightaway 250 is a sophisticated and versatile top hung system designed for heavy duty sliding doors up to 250kg. The system can easily accommodate large sliding doors in a variety of architectural openings and is supplied with four wheeled hangers incorporating nylon coated wheels and precision ball bearings.

### NOTE:

- All accessories to be ordered separately
- For more detailed information please refer to our Technical Data Sheet available on request

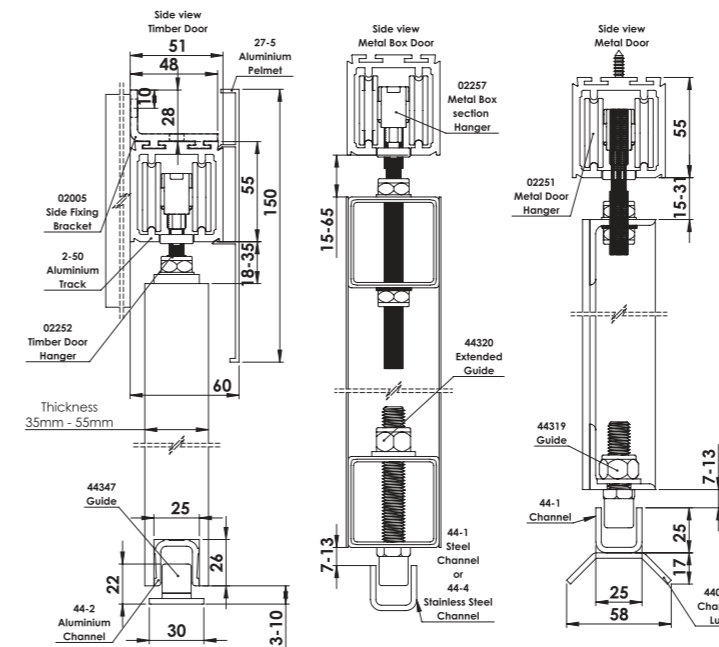

| Article No. | Finish/Size                      | Bottom Channel |
|-------------|----------------------------------|----------------|
| 44224       | Mill Finish, 25x25mm, 2400mm     |                |
| 44236       | Mill Finish, 25x25mm, 3600mm     |                |
| 44260       | Mill Finish, 25x25mm, 6000mm     |                |
| Article No. | Finish/Size                      | Fascia Pelmet  |
| 27501       | End caps for 27-5 Pelmet         |                |
| 27524       | Anodised Aluminium Pelmet 2400mm |                |
| 27530       | Anodised Aluminium Pelmet 3000mm |                |
| 27536       | Anodised Aluminium Pelmet 3600mm |                |
| 27560       | Anodised Aluminium Pelmet 6000mm |                |

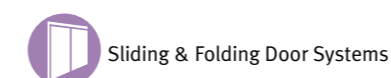

For further information please contact us:  
Tel: +44 (0)20 8545 6680 sales@coburn.co.uk www.coburn.co.uk



| Article No. | Finish/Size   | Track |
|-------------|---|-------|
| 25024       | Anodised Aluminium, 2400mm                                    |       |
| 25030       | Anodised Aluminium, 3000mm                                    |       |
| 25036       | Anodised Aluminium, 3600mm                                    |       |
| 25040       | Anodised Aluminium, 4000mm                                    |       |
| 25060       | Anodised Aluminium, 6000mm                                    |       |
| Article No. | Description   | Image |
| 02251       | 250 hanger for metal doors (pair)                             |       |
| 02252       | 250 hanger with concealed apron plate for timber doors (pair) |       |
| 02255       | 250 hanger with apron plate for timber doors (pair)           |       |
| 02257       | 250 hanger for box frame metal doors (pair)                   |       |
| 44354       | Adjustable wall mounted guide                                 |       |
| 44319       | Floor guide, pair, (metal doors)                              |       |
| 44320       | Extended floor guide (metal box frame doors)                  |       |
| 44347       | Concealed floor guide (timber doors)                          |       |
| 02718       | Track stop, (pair)  |       |
| 02005       | Face fixed bracket set (5 pcs)                                |       |
| 02006       | Face fixed bracket set (8 pcs)                                |       |
| 97741       | Microline   |       |
| 97791       | Telescopic 2 Door   |       |
| 97792       | Telescopic 3 Door   |       |
| 30641       | Soft closer 250 kg (concealed in track)                       |       |

## Door Specifications

- Maximum Door Weight: 250kg
- Door Thickness: 25-55mm
- Maximum Door Height: 4000mm
- Track Dimensions: 51mm (w) x 55mm (h)
- Track Dimensions for 25-9 track (soft closer) 53mm (w) x 64mm (h)

## Hardware Specifications

- Tracks can be ceiling mounted or face fixed
- Hangers manufactured with zinc cast solid bodies and delrin nylon outer wheels complete with precision ball bearings to ensure smooth and silent operation
- Variable height adjustment on doors
- Fittings available for timber, aluminium or metal doors
- Soft closing available for doors 810mm wide and over.
- Soft closing and soft opening available for doors 1240mm wide and over.





**Straightaway 600 Sliding & Folding Door System**

# Straightaway 600 Sliding Door Systems

## Product Overview

Straightaway 600 is a high calibre, heavy duty top hung system. The system is designed for interior and exterior sliding doors, with a maximum door weight of 600kg.

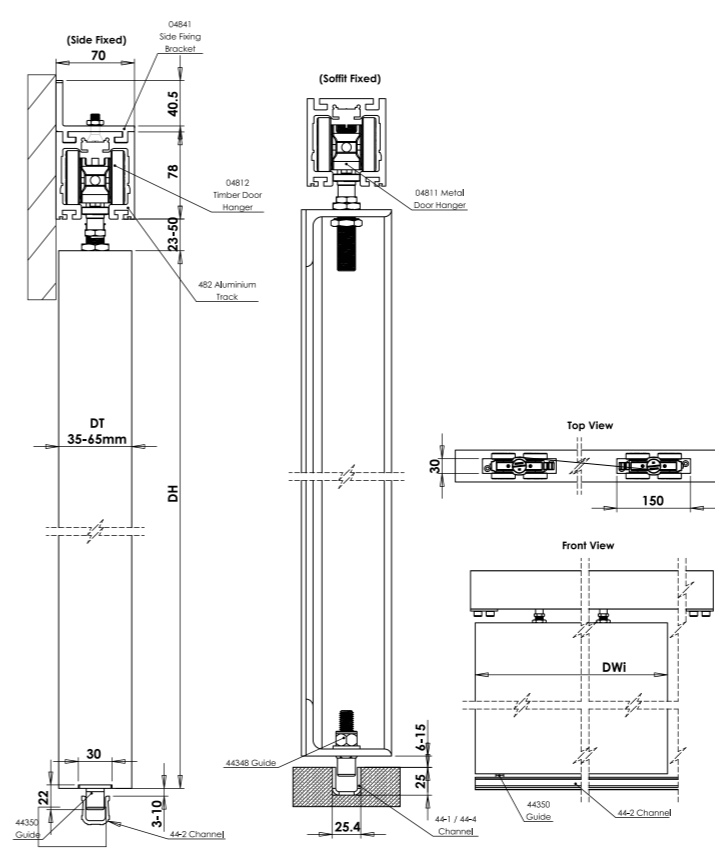

| Accessories |   |  |
|-------------|---|--|
| 95612       | Rectangular Flush Handle-Stainless Steel Finish 100x50x19mm           |  |
| 95625       | Stainless Steel round handle Diameter 90mm                            |  |
| 95626       | Stainless Steel round handle with concealed screw holes Diameter 90mm |  |
| 95628       | Stainless Steel handle with concealed screw holes 180 x 45mm          |  |
| 95629       | Stainless Steel handle with concealed screw holes 180 x 60mm          |  |

| Article No. | Finish/Size                     | Track |
|-------------|---------------------------------|-------|
| 48230       | Anodized aluminium track 3000mm |       |
| 48260       | Anodized aluminium track 6000mm |       |

| Article No. | Description  | Image |
|-------------|--|-------|
| 04841       | Side fixing bracket single   |       |
| 04842       | Side fixing brackets pack of 6   |       |
| 04843       | Side fixing brackets pack of 8   |       |
| 04811       | 4 wheel hanger for metal doors (pair)                                  |       |
| 04812       | 4 wheel hanger with concealed top fixing plate for timber doors (pair) |       |
| 04813       | 4 wheel hanger with edge fixing plate for timber doors (pair)          |       |
| 04814       | 4 wheel hanger with extended pendant bolt for metal doors (pair)       |       |
| 04821       | Track stop (pair)  |       |
| 44348       | Roller guide for metal doors (Pair)                                    |       |
| 44349       | Extended roller guide for metal doors (pair)                           |       |
| 44363       | Guide for timber doors (pair)  |       |
| 44350       | Roller guide for timber doors (pair)                                   |       |

| Article No. | Finish/Size                                | Bottom Channel |
|-------------|--|----------------|
| 44230       | Mill Finish aluminium channel 3000mm       |                |
| 44260       | Mill Finish aluminium channel 6000mm       |                |
| 44130       | Galvanised Finish steel channel 3000mm     |                |
| 44430       | Mill Finish stainless steel channel 3000mm |                |
| 44530       | Mill Finish aluminium channel 3000mm       |                |
| 44560       | Mill Finish aluminium channel 6000mm       |                |
| 49230       | Polypropylene channel 3000mm               |                |
| 49260       | Polypropylene channel 6000mm               |                |

### Door Specifications

- Maximum Door Weight: 600kg
- Door Thickness: 30-65mm
- Maximum Door Height: 6000mm
- Track Dimensions: 70mm (w) x 78mm (h)

### Hardware Specifications

- Variable height adjustment
- Manufactured from grade 304 Stainless Steel
- Soffit fixed or wall mounted
- Fittings available for timber, aluminium or metal doors

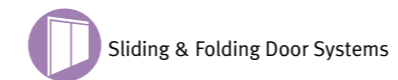

For further information please contact us:  
Tel: +44 (0)20 8545 6680 sales@coburn.co.uk www.coburn.co.uk







Microline Sliding & Folding Door Systems

# Microline

## Sliding Door Systems

### Product Overview

The Microline Installation Kit moves the suspension profile for timber sliding doors from above the door to within the door enabling you to reduce the clearance between the track and the top of the door leaf. The Kit is engineered for simple fitting, allows for easy adjustment after fitting and allows you to achieve the minimum installation height.

| Article No. | Description | Image |
|-------------|-------------|-------|
| 97741       | Microline   |       |

**NOTE:**

- All accessories to be ordered separately
- For more detailed information please refer to our Technical Data Sheet available on request

| System                              | Door to Track Gap<br>Without Microline | Door to Track Gap<br>With Microline | Door Thickness Range<br>Using Microline | Maximum Door Weight |
|-------------------------------------|--|-------------------------------------|---|---------------------|
| • Straightaway 100                  | 20-32mm                                | 2-11mm                              | 30-50mm                                 | 100kg               |
| • Straightaway 130<br>• Eternal 130 | 20-35mm                                | 2-11mm                              | 30-50mm                                 | 130kg               |
| • Straightaway 180<br>• Eternal 180 | 18-32mm                                | 2-11mm                              | 30-55mm                                 | 180kg               |
| • Straightaway 250<br>• Eternal 250 | 18-35mm                                | 2-11mm                              | 30-55mm                                 | 250kg               |

### Door Specifications

- Maximum Door Weight: 250kg
- Door Thickness: 30-55mm
- Maximum Door Height: 4000mm
- Door Construction: Timber doors only

### Hardware Specifications

- Reduces the clearance between the track and the top of the door to as little as 2mm
- Kits can be retro-fitted to existing sliding door applications
- Device recessed into and concealed in the top of the door
- Fittings fully concealed by end caps
- Allows perpendicular height adjustment of up to 9mm

### Microline Specifications

Minimum door thickness: 30mm  
Maximum door weight is 250kg  
(depending on system used)

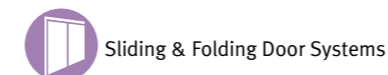
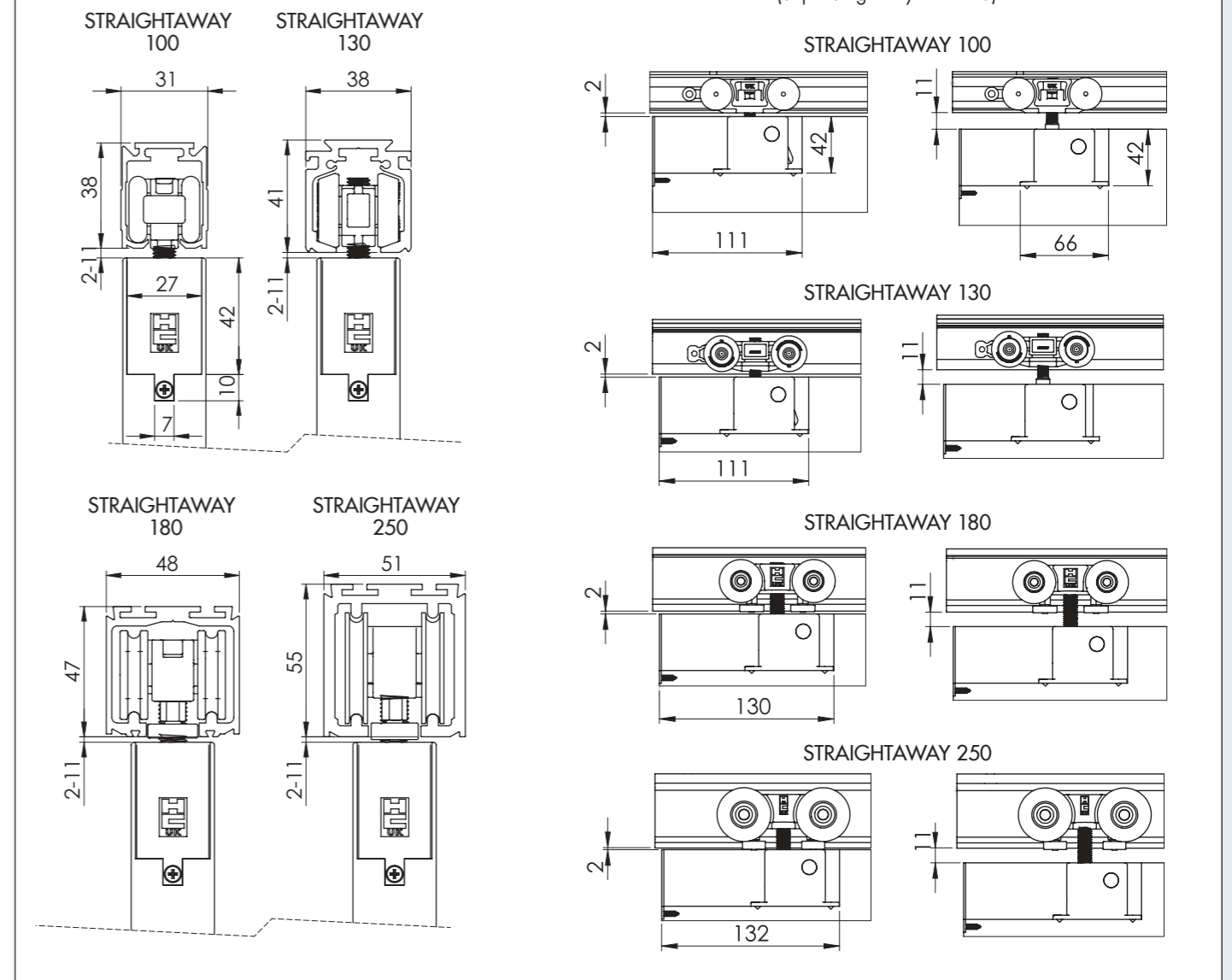

For further information please contact us:  
Tel: +44 (0)20 8545 6680 sales@coburn.co.uk www.coburn.co.uk





Straightaway Telescopic Sliding & Folding Door Systems

### Door Specifications

- Maximum Door Weight: 250kg
- Door Thickness: 30-50mm
- Maximum Door Height: 4000mm
- Minimum Door Width: 500mm
- Maximum Door Width: 1500mm (for wider doors please contact our Sales Team)
- Door Construction: Timber doors only

### Hardware Specifications

- Suitable for 2 or 3 doors sliding in one direction
- Can be used with Straightaway 100,130,180 & 250 systems
- No recessed channels or floor guides giving a clear threshold
- Maintenance free heavy duty 10mm toothed belt



# Straightaway Telescopic Sliding Door Systems

## Product Overview

The Straightaway Telescopic system enables 2 or 3 timber doors to open and close harmoniously and stack discreetly to the side of the opening allowing wider passageway options than single sliding leaf doors whilst making more efficient use of building space. The heavy duty toothed belt and pulley that connects the doors means that moving the lead door moves all of the doors simultaneously and smoothly at differing speeds. The channel free guiding method eliminates dust traps and trip hazards.

| Article No. | Finish/Size       | Image |
|-------------|-------------------|-------|
| 97791       | Telescopic 2 Door |       |
| 97792       | Telescopic 3 Door |       |

### NOTE:

- All accessories to be ordered separately
- For more detailed information please refer to our Technical Data Sheet available on request

**LEGEND:**  
 OL = DOOR OVERLAP  
 G = GAP BETWEEN DOORS  
 DT = DOOR THICKNESS  
 DW = DOOR WIDTH  
 OW = OPENING WIDTH  
 ALL DIMENSIONS ARE IN MM

**STRAIGHTAWAY 100**

Minimum door thickness: 30mm  
 Maximum door thickness: 50mm  
 Maximum door weight: 100kg  
 Minimum door width: 500mm  
 Maximum door width: 1500mm  
 Minimum recommended Overlap (OL): 30mm  
 Minimum recommended gap (G) is 6mm  
 Minimum gap can be achieved with all door widths, in accordance with the gap between the tracks

| SYSTEM | WEIGHT | DOOR THICKNESS | DOOR WIDTH (MIN) | DOOR WIDTH (MAX) | OVERLAP (MIN) | G (MIN)   |
|--------|--------|----------------|------------------|------------------|---------------|-----------|
| ST 100 | 100kg  | 30mm - 50mm    | 500mm            | 1500mm           | 30mm          | 6mm       |
| ST 130 | 130kg  | 30mm - 50mm    | 500mm            | 1500mm           | 30mm          | 6mm - 8mm |
| ST 180 | 180 kg | 39mm - 50mm    | 500mm            | 1500mm           | 30mm          | 6mm - 9mm |
| ST 250 | 250 kg | 43mm - 50mm    | 500mm            | 1500mm           | 30mm          | 6mm - 9mm |





Flat Track Mini Sliding & Folding Door System

### Product Overview

Flat Track Mini is a lighter version of the Coburn Flat Track range. It offers a traditional rustic look and is ideal for barn conversions, cottages, etc for doors up to 50kg. The exposed hardware is available in a black powder coated finish as standard finish and its nylon bearing wheels ensure the hangers move smoothly and silently across the flat bar.

### Door Specifications

- Maximum Door Weight: 50Kg
- Door Thickness: 25mm - 38mm
- Door Construction: Timber doors only

### Hardware Specifications

- Durable steel strap hangers with Nylon wheels
- Nylon wheels supplied with precision sealed ball bearings.
- Anti-jump blocks prevent door coming off the track.
- Choice of hanger styles available.

## Flat Track Mini Sliding Door Systems

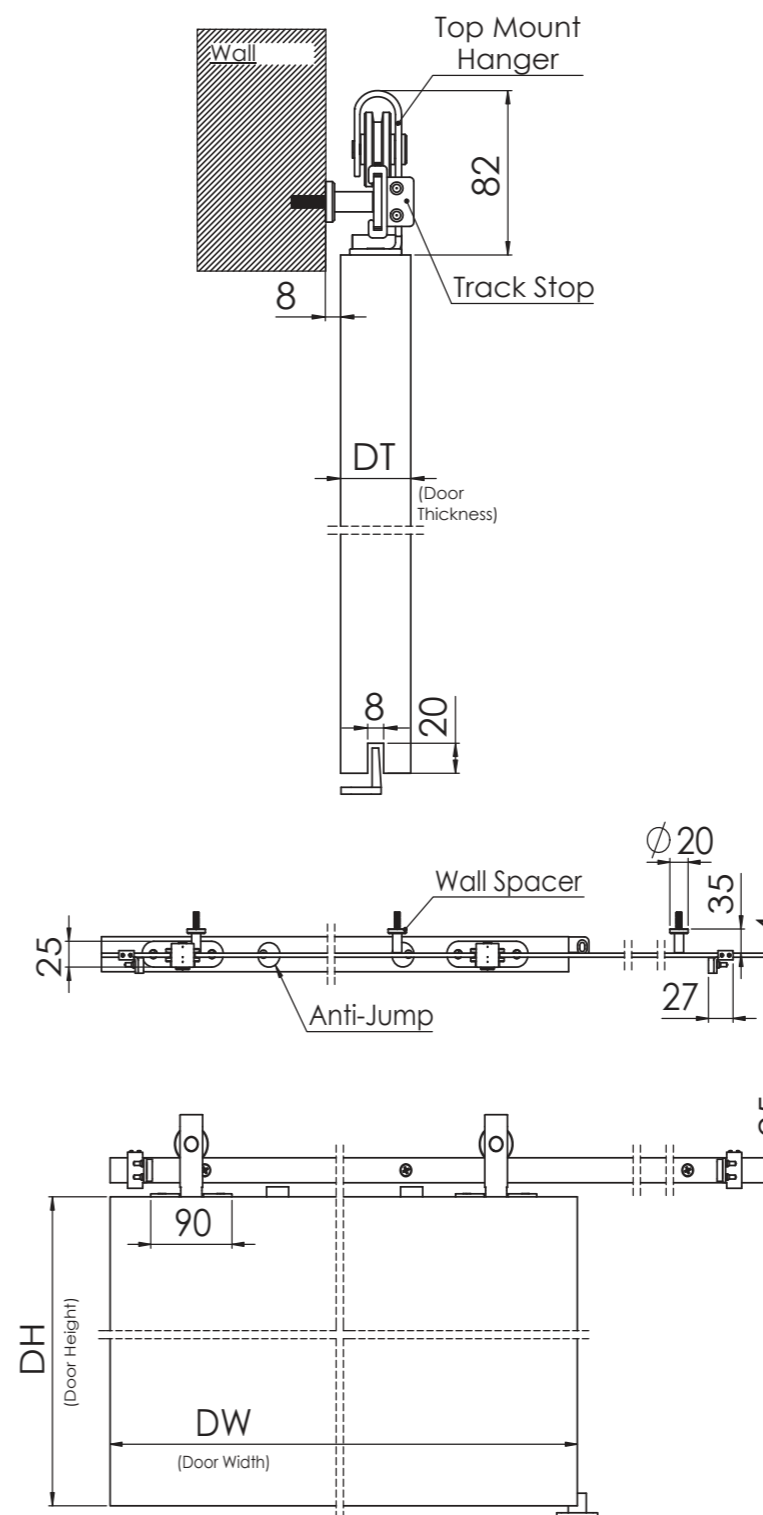

#### NOTE:

- All accessories to be ordered separately
- For more detailed information please refer to our Technical Data Sheet available on request



Sliding & Folding Door Systems

For further information please contact us:  
Tel: +44 (0)20 8545 6680 sales@coburn.co.uk www.coburn.co.uk



| Article No. | Description   | Image |
|-------------|---|-------|
| 41151       | Trackset for one door up to 750mm<br>Straight Hanger - Black Finish   |       |
| 41152       | Trackset for one door up to 1000mm<br>Straight Hanger - Black Finish  |       |
| 41153       | Trackset for one door up to 750mm<br>Arrow Head Hanger- Black Finish  |       |
| 41154       | Trackset for one door up to 1000mm<br>Arrow Head Hanger- Black Finish |       |
| 41155       | Trackset for one door up to 750mm<br>Top Mount Hanger- Black Finish   |       |
| 41156       | Trackset for one door up to 1000mm<br>Top Mount Hanger- Black Finish  |       |
| 41158       | Joining Bracket - Black Finish  |       |
| 30658       | Soft Closer Kit up to 50 kg   |       |
| 41033       | Bow Handle - Black Finish   |       |
| 41034       | Rectangular Flush Handle<br>111x43 mm - Black Finish                  |       |
| 95630       | Rectangular Flush Pull Handle<br>180x45mm - Black Finish              |       |
| 41159       | Extended spacers (pack of 4)<br>35 mm - Black Finish                  |       |
| 41160       | Extended spacers (pack of 5)<br>35 mm - Black Finish                  |       |



## Flat Track Range Sliding & Folding Door Systems

### Product Overview

The Flat Track range is a sliding hardware system with exposed fittings and is offered with a choice of finishes and hanger styles which enables the installer to create a retro or contemporary look. The Flat Track range offers aesthetic appeal and versatility including soft closing and bi-passing bracket options without compromising on performance.

#### NOTE:

- All accessories to be ordered separately
- For more detailed information please refer to our Technical Data Sheet available on request

### Door Specifications

- Maximum Door Weight: 360kg
- Door Thickness: 35-75mm
- Minimum Door Width: 550mm
- Door Construction: Timber doors only

### Hardware Specifications

- 3 systems in range with maximum door weight capacities of 100kg, 180kg, 360kg
- Anti-jump blocks prevent door being dislodged from the track
- For internal use only
- Choice of hanger styles and finishes available
- Soft closing and bi-passing bracket options
- Various tracksets available for both single doors and bi-parting doors

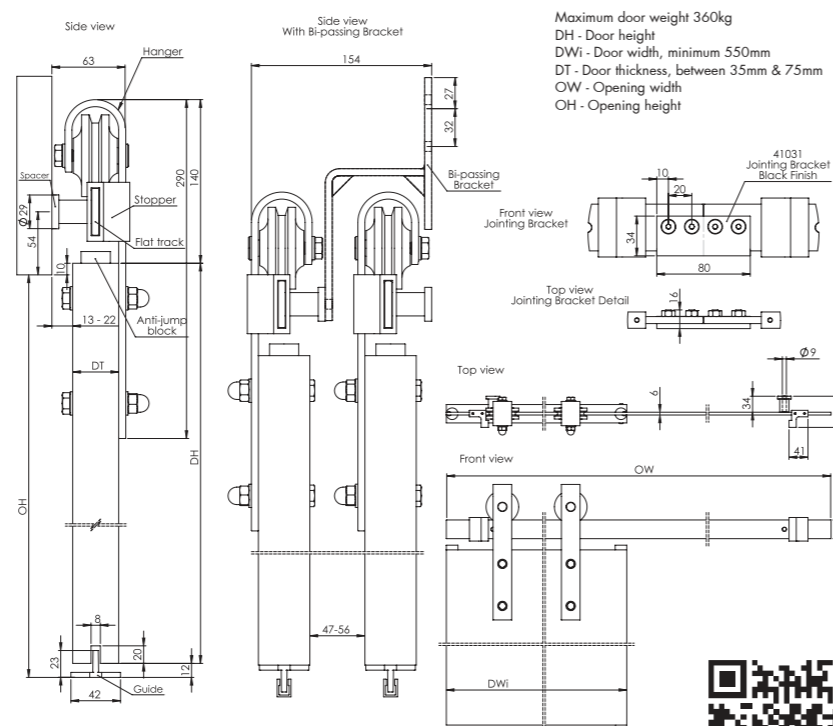

## Flat Track Range Sliding Door Systems

| Flat Track 100 |  |       |
|----------------|--|-------|
| Article No.    | Description  | Image |
| 41020          | Trackset for one door up to 1000mm – straight hanger – black finish            |       |
| 41030          | Trackset for one door up to 1500mm – straight hanger – black finish            |       |
| 41041          | Trackset for one door up to 1000mm – straight hanger – rust finish             |       |
| 41042          | Trackset for one door up to 1500mm – straight hanger – rust finish             |       |
| 41043          | Trackset for one door up to 1000mm – straight hanger – stainless steel finish  |       |
| 41044          | Trackset for one door up to 1500mm – straight hanger – stainless steel finish  |       |
| 41045          | Trackset for one door up to 1000mm – wagon wheel hanger – black finish         |       |
| 41046          | Trackset for one door up to 1500mm – wagon wheel hanger – black finish         |       |
| 41047          | Trackset for one door up to 1000mm – top mount hanger – black finish           |       |
| 41048          | Trackset for one door up to 1500mm – top mount hanger – black finish           |       |
| 41049          | Trackset for one door up to 1000mm – top mount hanger – stainless steel finish |       |
| 41050          | Trackset for one door up to 1500mm – top mount hanger – stainless steel finish |       |
| 41051          | Trackset for one door up to 1000mm – arrowhead hanger – black finish           |       |
| 41052          | Trackset for one door up to 1500mm – arrowhead hanger – black finish           |       |
| 41053          | Trackset for one door up to 1000mm – arrowhead hanger – rust finish            |       |
| 41054          | Trackset for one door up to 1500mm – arrowhead hanger – rust finish            |       |
| 41031          | Joining bracket – black finish   |       |
| 41036          | Joining bracket – rust finish  |       |
| 41037          | Joining bracket – stainless steel finish                                       |       |
| 41032          | Bracket for bi-passing doors – black finish                                    |       |
| 41025          | Bracket for bi-passing doors – rust finish                                     |       |
| 41024          | Bracket for bi-passing doors – stainless steel finish                          |       |
| 30640          | Soft closer kit – up to 100kg  |       |
| Flat Track 180 |  |       |
| 41011          | Trackset for one door up to 914mm – straight hanger – black finish             |       |
| 41012          | Trackset for one door up to 1219mm – straight hanger – black finish            |       |
| 41013          | Kit to suit 762mm double doors – straight hanger – black finish                |       |
| 41014          | Trackset for one door up to 914mm – straight hanger – brushed nickel finish    |       |
| 41015          | Trackset for one door up to 1219mm – straight hanger – brushed nickel finish   |       |
| 41016          | Kit to suit 762mm double doors – straight hanger – brushed nickel finish       |       |

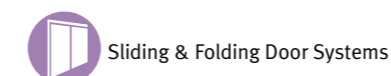

For further information please contact us:  
 Tel: +44 (0)20 8545 6680 sales@coburn.co.uk www.coburn.co.uk

| Article No.    | Description                                       | Image          |
|----------------|---|----------------|
| 46318          | 180 Flat track 1828mm with 4 spacers black finish |                |
| 46324          | 180 Flat track 2438mm with 5 spacers black finish |                |
| 46330          | 180 Flat track 3048mm with 7 spacers black finish |                |
| 46043          | 180 Flat track door stop – black finish           |                |
| 46402          | 180 Flat track hanger – black finish              |                |
| 47044          | Flat track anti jump block                        |                |
| 46042          | 180 Flat track splice plate – black finish        |                |
| 22392          | Nylon floor guide                                 |                |
| Article No.    | Description                                       | Bottom Channel |
| 41215          | Mill Finish, 12x15mm, 1500mm                      |                |
| 41218          | Mill Finish, 12x15mm, 1800mm                      |                |
| 41221          | Mill Finish, 12x15mm, 2100mm                      |                |
| 41224          | Mill Finish, 12x15mm, 2400mm                      |                |
| 41230          | Mill Finish, 12x15mm, 3000mm                      |                |
| 41236          | Mill Finish, 12x15mm, 3600mm                      |                |
| 41260          | Mill Finish, 12x15mm, 6000mm                      |                |
| Flat Track 360 |   |                |
| 47324          | 360 Flat track 2438mm with 5 spacers black finish |                |
| 47330          | 360 Flat track 3048mm with 7 spacers black finish |                |
| 47043          | 360 Flat track door stop – black finish           |                |
| 46405          | 360 Flat track hanger – black finish              |                |
| 47042          | 360 Flat track splice plate – black finish        |                |
| 44347          | Concealed fixing nylon roller guide               |                |
| Article No.    | Description                                       | Bottom Channel |
| 44215          | Mill Finish, 25x25mm, 1500mm                      |                |
| 44218          | Mill Finish, 25x25mm, 1800mm                      |                |
| 44221          | Mill Finish, 25x25mm, 2100mm                      |                |
| 44224          | Mill Finish, 25x25mm, 2400mm                      |                |
| 44230          | Mill Finish, 25x25mm, 3000mm                      |                |
| 44236          | Mill Finish, 25x25mm, 3600mm                      |                |
| 44260          | Mill Finish, 25x25mm, 6000mm                      |                |
| Accessories    |   |                |
| 41033          | Bow handle – black finish                         |                |
| 41034          | Flush handle – black finish                       |                |
| 41035          | Round flush handle – rust finish                  |                |
| 95612          | Flush handle – stainless steel finish             |                |
| 41040          | WallGuide – black finish                          |                |

#### NOTE:

- Longer spacers available on request.





Vetroslide Timber - Sliding & Folding Door System

### Door Specification

- Maximum Door Weight: 100kg
- Minimum Door Width: 550mm
- Maximum Door Width: 1000mm
- Door Thickness: 35 - 45mm

### Hardware Specification

- Nylon coated wheels supplied with precision sealed ball bearings
- Anti-jump bar prevents door from being removed from track
- Soft closing as standard, concealed inside the round track
- Choice of hanger styles available on request.

## Vetroslide Timber Sliding Door System

### Product Overview

Vetroslide Timber sliding hardware offers contemporary look for doors up to 100 kg.

The hardware is manufactured from grade 304 Stainless Steel with a satin brushed finish. The nylon coated bearing wheels ensure the hangers move freely and silently on top of the round bar.

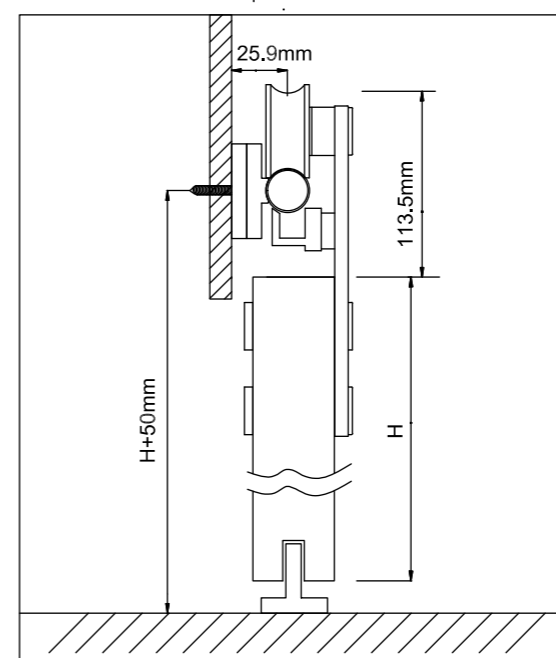
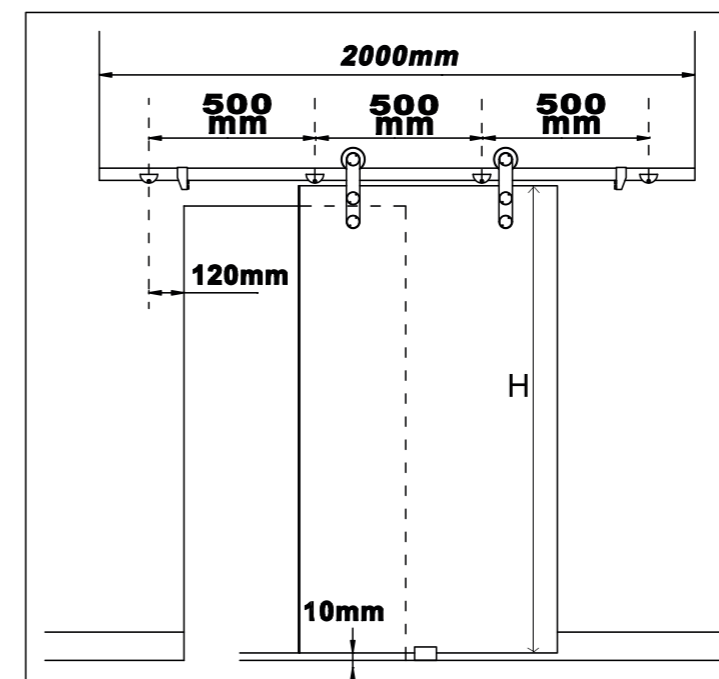

#### NOTE:

- All accessories to be ordered separately
- For more detailed information please refer to our Technical Data Sheet available on request



Sliding & Folding Door Systems



For further information please contact us:

Tel: +44 (0)20 8545 6680 sales@coburn.co.uk www.coburn.co.uk

| Article No. | Finish/Size  | Image |
|-------------|--|-------|
| 41281       | Trackset for one Timber Door up to 750 mm Straight Single Wheel Hanger - SS Brush Finish   |       |
| 41282       | Trackset for one Timber Door up to 900 mm Straight Single Wheel Hanger - SS Brush Finish   |       |
| 41283       | Trackset for one Timber Door up to 1000 mm Straight Single Wheel Hanger - SS Brush Finish  |       |
| 41284       | Trackset for one Timber Door up to 750 mm Top mount Single Wheel Hanger - SS Brush Finish  |       |
| 41285       | Trackset for one Timber Door up to 900 mm Top mount Single Wheel Hanger - SS Brush Finish  |       |
| 41286       | Trackset for one Timber Door up to 1000 mm Top mount Single Wheel Hanger - SS Brush Finish |       |
| 41287       | Trackset for one Timber Door up to 750 mm Top mount Double Wheel Hanger - SS Brush Finish  |       |
| 41288       | Trackset for one Timber Door up to 900 mm Top mount Double Wheel Hanger - SS Brush Finish  |       |
| 41289       | Trackset for one Timber Door up to 1000 mm Top mount Double Wheel Hanger - SS Brush Finish |       |
| Article No. | Description  | Image |
| 95612       | Rectangular Flush Handle-Stainless Steel Finish 100x50x19mm                                |       |
| 95625       | Stainless Steel round handle Diameter 90mm   |       |
| 95626       | Stainless Steel round handle with concealed screw holes Diameter 90mm                      |       |
| 95628       | Stainless Steel handle with concealed screw holes 180 x 45mm                               |       |
| 95629       | Stainless Steel handle with concealed screw holes 180 x 60mm                               |       |



Trackless System - Sliding & Folding Door Systems

# Trackless System

## Sliding Door Systems

### Product Overview

Coburn Trackless is a totally hidden hardware system for internal sliding timber doors.

Attractive modern minimalist design is achieved with the sliding track fixed to the rear side of the door and the rollers fixed to the wall allowing the door to be installed at any height and giving the impression of a floating door.

Three way adjustment ensures that the function matches the impressive sleek aesthetics of the system.

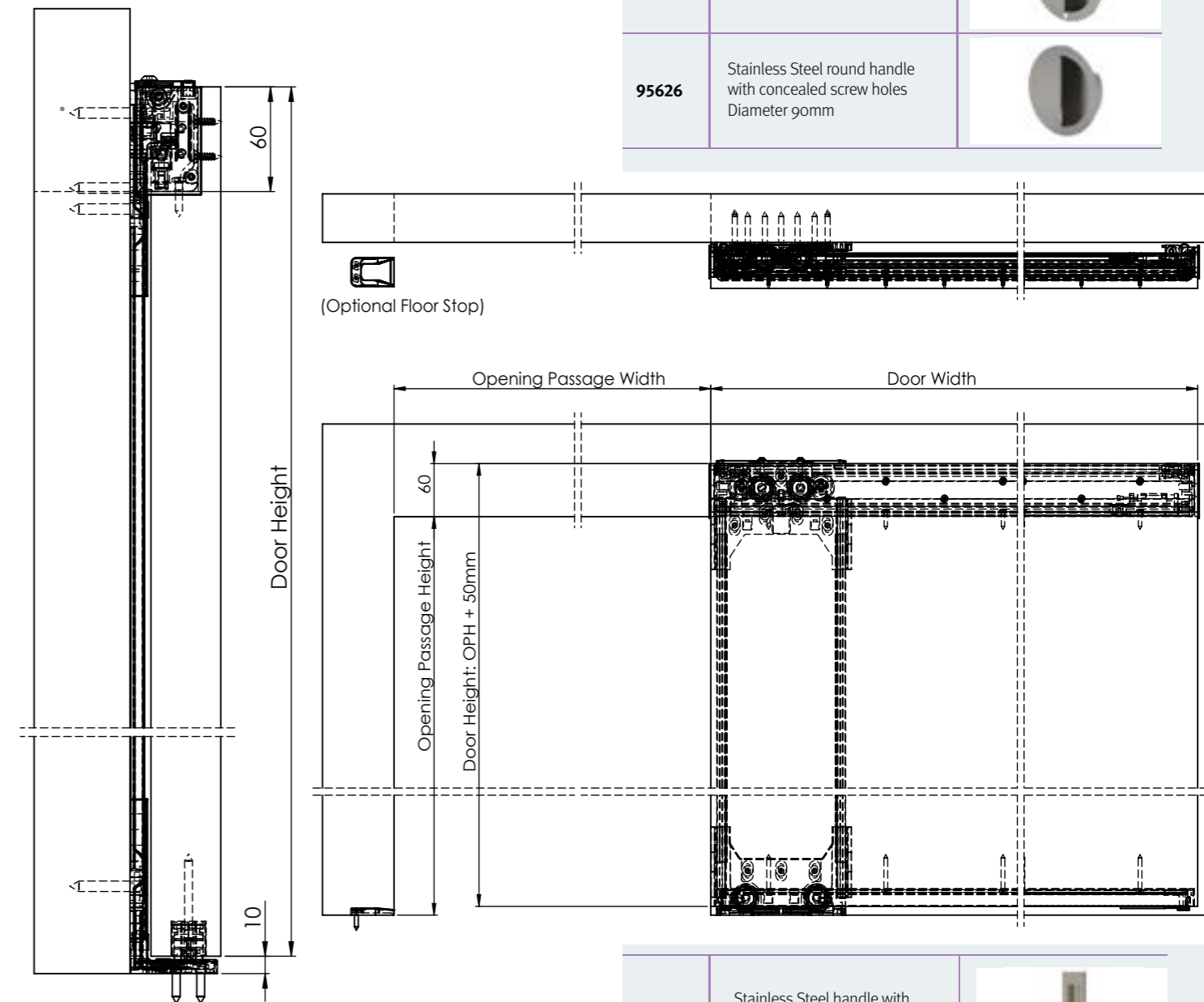

#### NOTE:

- All accessories to be ordered separately
- For more detailed information please refer to our Technical Data Sheet available on request

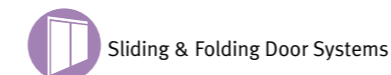

| Article No. | Finish/Size   | Track |
|-------------|---|-------|
| 71901       | Trackless 1 Door Complete Kit upto 1200mm wide door                   |       |
| Article No. | Description   | Image |
| 95612       | Rectangular Flush Handle-Stainless Steel Finish 100x50x19mm           |       |
| 95625       | Stainless Steel round handle Diameter 90mm                            |       |
| 95626       | Stainless Steel round handle with concealed screw holes Diameter 90mm |       |

|       |  |  |
|-------|--|--|
| 95628 | Stainless Steel handle with concealed screw holes 180 x 45mm |  |
| 95629 | Stainless Steel handle with concealed screw holes 180 x 60mm |  |

### Door Specification

- Maximum Door Weight: 50kg
- Door Thickness: 40-50mm
- Maximum Door Height: 2450mm
- Maximum Door Width: 1200mm

### Hardware Specification

- Standard kit can be cut to smaller door requirements.
- Track recessed and concealed on top of the door.
- No hardware fixed on the floor, perfect solution for under floor heating.
- Fittings fully concealed by end caps.
- Vertical and lateral adjustment.
- For internal use only.





Duo Swing Sliding & Folding Door Systems

### Door Specifications

- Maximum Door Weight: 70kg
- Door Thickness: 35-50mm
- Door Width: 686mm, 762mm or 838mm (for wider doors please contact our Sales Team)
- Maximum Door Height: 1981mm (for taller doors please contact our Sales Team)
- Door Construction: Timber doors only

### Hardware Specifications

- Aluminium track
- Easy manual operation
- Vertical and lateral adjustment
- Soft opening available
- No alteration of the wall required
- Uses rototranslation technology, a space saving alternative to swing doors



## Duo Swing Sliding Door Systems

### Product Overview

Duoswing has been developed to minimise the footprint of the swing area whilst maintaining the opening width of a conventional door. Whereas a standard hinged door is hinged on the edge of the door Duoswing uses top and bottom pivots and a sliding door track to enable the door to open with half of it either side of the frame. This simultaneous rotation and swing movement of the door leaf during the opening and/or closing stages saves 50% of the space a conventional swing door takes up.

#### NOTE:

- All accessories to be ordered separately
- For more detailed information please refer to our Technical Data Sheet available on request

| Article No. | Finish/Size                          | Image |
|-------------|--------------------------------------|-------|
| 61201       | Kit to suit door size 686mm x 1981mm |       |
| 61202       | Kit to suit door size 762mm x 1981mm |       |
| 61203       | Kit to suit door size 838mm x 1981mm |       |
| 61207       | Pair of Tanganika vertical uprights  |       |
| 61208       | Soft opening kit                     |       |

#### Contents per set:

Aluminium top track, top and bottom pivot arm, corner bracket, threaded rod, rod guide, rod connector, suspension roller with plate, ball catch, door lock, brush strips.

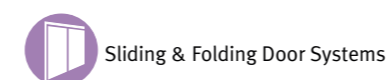
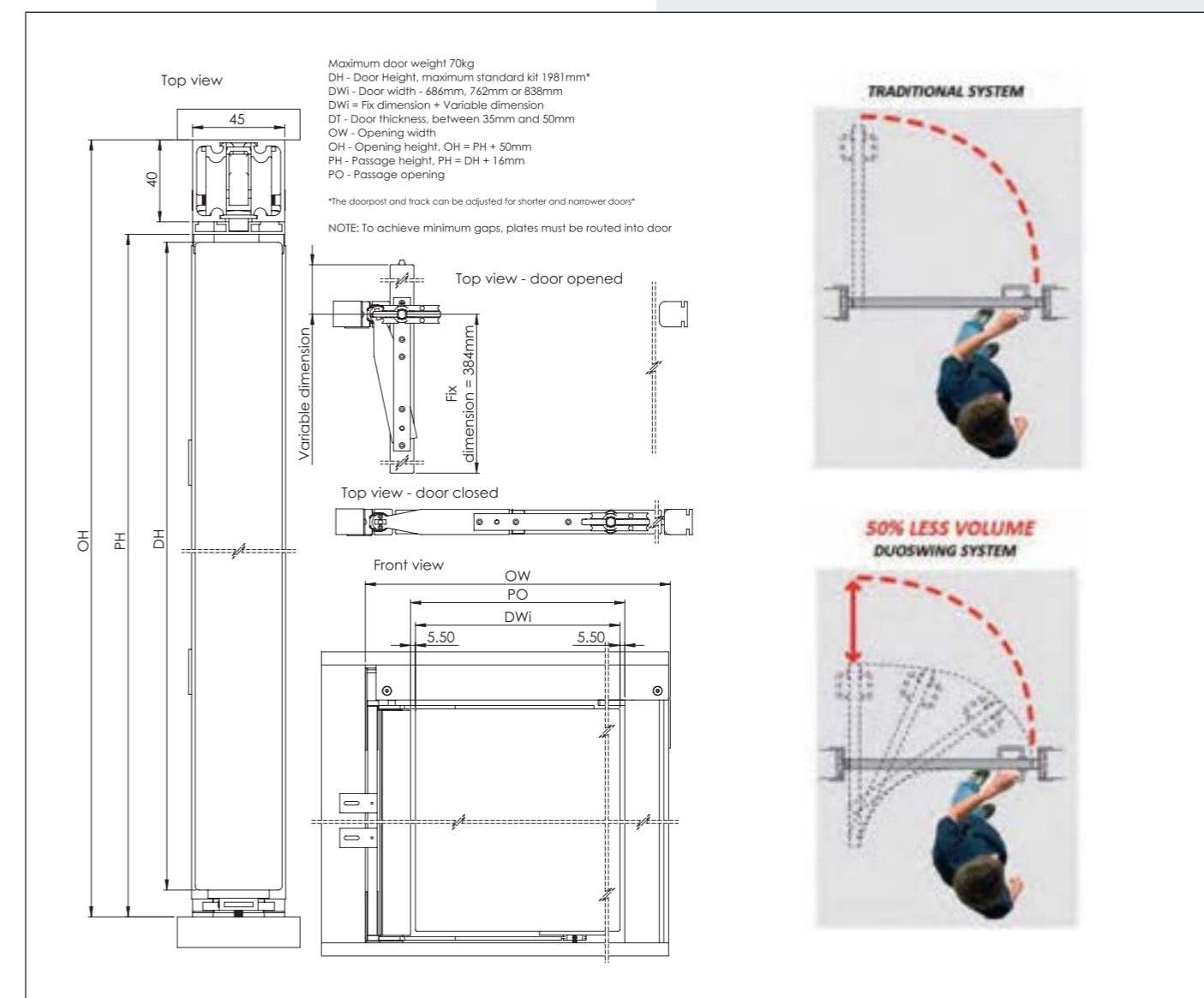

For further information please contact us:  
Tel: +44 (0)20 8545 6680 sales@coburn.co.uk www.coburn.co.uk



Folding 180 - Sliding & Folding Door Systems

### Door Specification

- Maximum Door Weight: 50kg per mechanism
- Door Thickness: 40-44mm
- Maximum Door Height: 3000mm
- Maximum opening Width: 1100mm

### Hardware Specification

- Reduces door clearance needs and maximises usable space.
- Areas around doorways can be redesigned to benefit from the the extra space created.
- The door folds in half and back against the wall, reducing space requirement by half.
- No more problems of conflict between adjacent doors.
- When closed, the door becomes a single element like a normal door.
- Kits available in different sizes and handing.

## Folding 180

### Folding Door Systems

#### Product Overview

Folding 180 uses rototranslating door technology to allow doors to fold back 180 degrees allowing the panels to sit flat against the return wall when in the open position, leaving the room free from any protruding doors, saving space and eliminating obstructions. Folding 180 is a track and channel free hinge system with no sliding elements giving a stable and silent action. As well as being an innovative substitute for more traditional folding door systems. Folding 180 can also be used as a space saving alternative to swing doors.

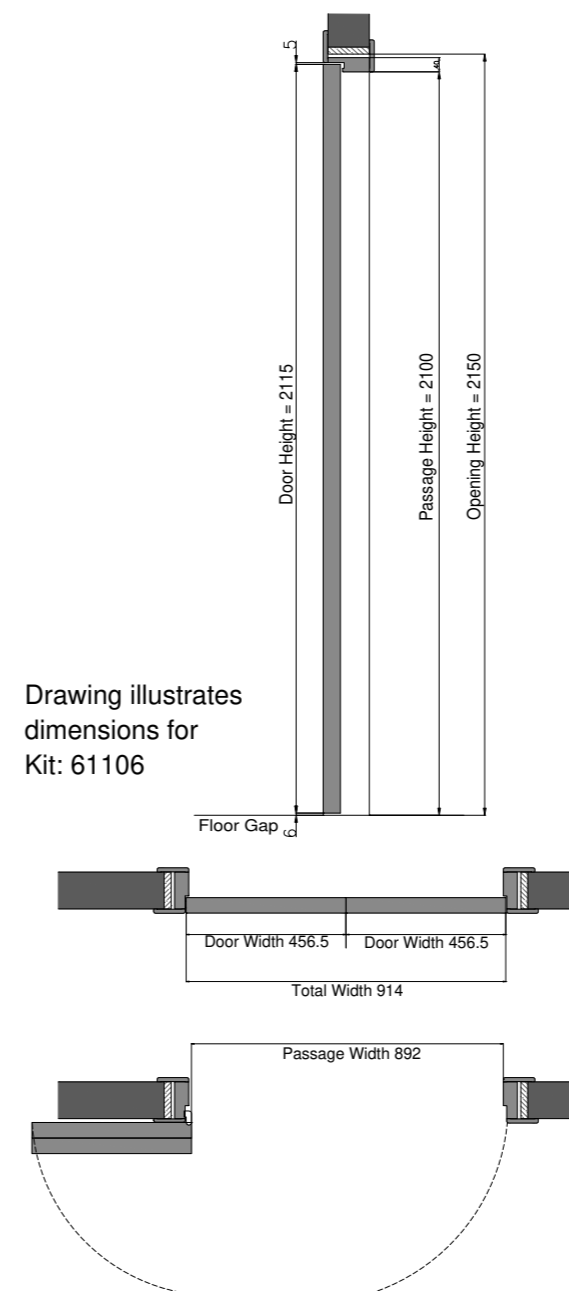

Drawing illustrates dimensions for Kit: 61106

- NOTE:**
- All accessories to be ordered separately
  - For more detailed information please refer to our Technical Data Sheet available on request

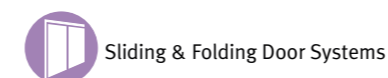

For further information please contact us:  
Tel: +44 (0)20 8545 6680 sales@coburn.co.uk www.coburn.co.uk



| Article No. | Finish/Size  | Image     |
|-------------|--|-----------|
| 61101       | Folding 180 Kit SS Brush Finish 700 mm - Opening - Right Hand  |           |
| 61102       | Folding 180 Kit SS Brush Finish 700 mm - Opening - Left Hand   |           |
| 61103       | Folding 180 Kit SS Brush Finish 800 mm - Opening - Right Hand  |           |
| 61104       | Folding 180 Kit SS Brush Finish 800 mm - Opening - Left Hand   |           |
| 61105       | Folding 180 Kit SS Brush Finish 900 mm - Opening - Right Hand  |           |
| 61106       | Folding 180 Kit SS Brush Finish 900 mm - Opening - Left Hand   |           |
| 61107       | Folding 180 Kit SS Brush Finish 1000 mm - Opening - Right Hand |           |
| 61108       | Folding 180 Kit SS Brush Finish 1000 mm - Opening - Left Hand  |           |
| 61109       | Folding 180 Kit SS Brush Finish 1100 mm - Opening - Right Hand |           |
| 61110       | Folding 180 Kit SS Brush Finish 1100 mm - Opening - Left Hand  |           |
| Article No. | Finish/Size  | Mag Lock  |
| 61121       | Magnetic Lock  |           |
| Article No. | Finish/Size  | Push & Go |
| 61122       | Push n Go, Push to open bolt                                   |           |





# Foldaside 30

## Folding Door Systems

### Product Overview

Foldaside 30 is a reliable hardware system purpose designed for lightweight internal folding doors up to 30kg per leaf. The end door within the set is secured using a pivot bearing whilst the other doors are aligned by means of unobtrusive hinges and hangers that bring the panels together.

#### NOTE:

- All accessories to be ordered separately
- For more detailed information please refer to our Technical Data Sheet available on request

| Article No. | Description  | Image |
|-------------|--|-------|
| 01211       | Foldaside 30, 2 door fitting kit with tracks and channel |       |
| 01212       | Foldaside 30, 3 door fitting kit with tracks and channel |       |
| 01213       | Foldaside 30, 4 door fitting kit with tracks and channel |       |

| Article No. | Description               | Component Packs |
|-------------|---------------------------|-----------------|
| 01231       | Two door component pack   |                 |
| 01232       | Three door component pack |                 |
| 01233       | Four door component pack  |                 |

### Foldaside 30 Sliding & Folding Door Systems



#### Door Specifications

- Maximum Door Weight: 30kg
- Door Thickness: 20-40mm
- Maximum Door Height: 2500mm
- Maximum Door Width: 600mm
- Track Dimensions: 27mm (w) x 24.5mm (h)

#### Hardware Specifications

- For timber, timber framed or composite doors
- No recessed floor channel necessary with 2 leaf configurations
- A maximum of four doors can be hinged together
- Suitable for odd or even suites of doors
- Stable and smooth operation
- Concealed hinges come as standard
- Optional matt black finish door furniture available.

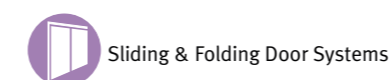
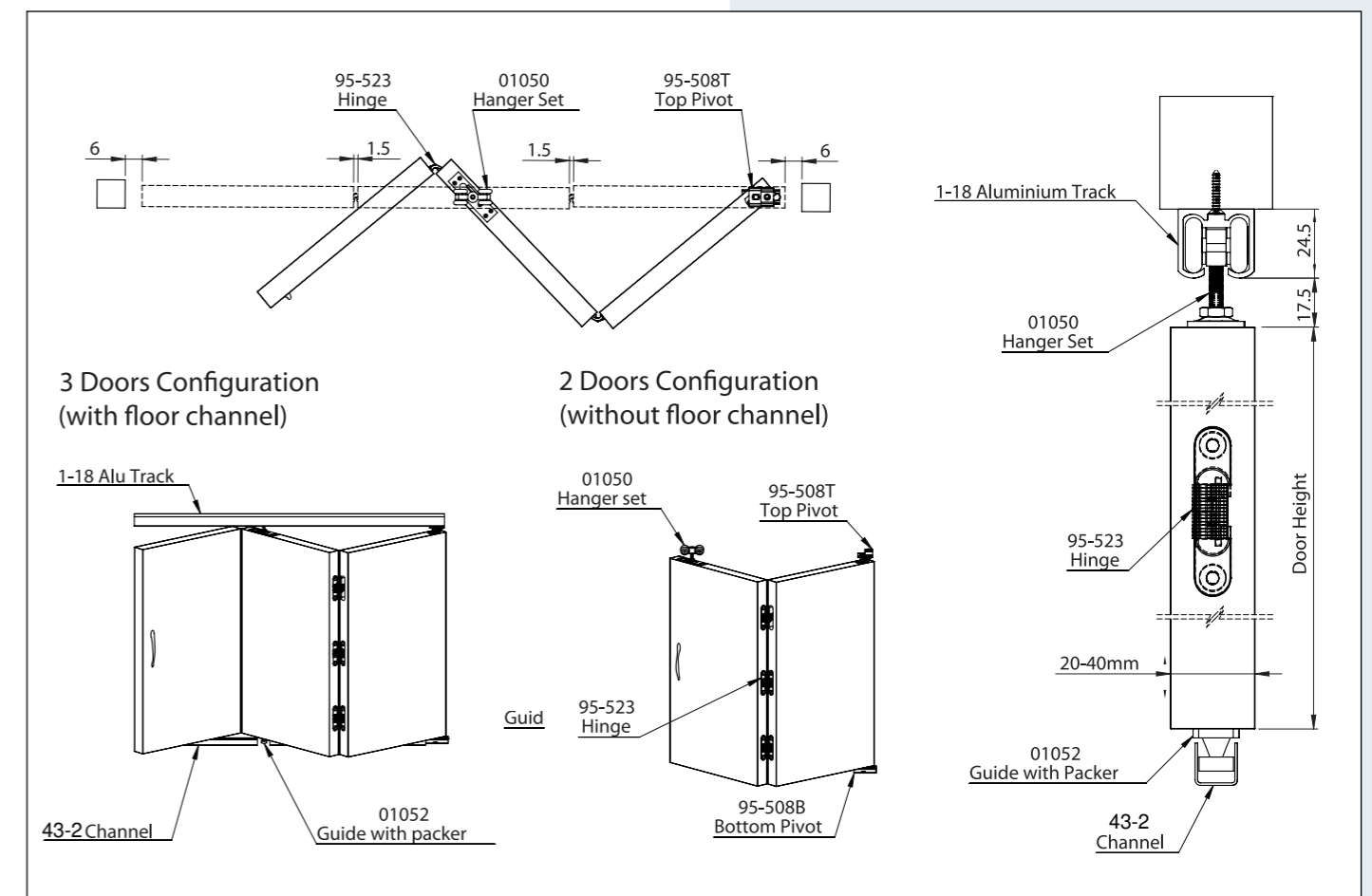

For further information please contact us:  
Tel: +44 (0)20 8545 6680 sales@coburn.co.uk www.coburn.co.uk





Foldaside 50 Sliding & Folding Door Systems

### Door Specifications

- Maximum Door Weight: 50kg
- Door Thickness: 30-50mm
- Maximum Door Height: 3000mm
- Maximum Door Width: 850mm
- Track Dimensions: 48mm (w) x 47mm (h)

### Hardware Specifications

- For timber, timber framed or composite doors
- Neatly stacking to either one or both sides
- No recessed floor channel necessary with 2 or 3 leaf configurations
- A maximum of six doors can be hinged together
- Suitable for odd or even suites of doors
- Stable and smooth operation
- Concealed hinges optional

# Foldaside 50

## Folding Door Systems

### Product Overview

Foldaside 50 is a reliable hardware system purpose designed for internal folding doors up to 50kg per leaf.

The end door within the set is secured using a pivot bearing whilst the other doors are aligned by means of unobtrusive hinges and hangers that bring the panels together.

#### NOTE:

- All accessories to be ordered separately
- For more detailed information please refer to our Technical Data Sheet available on request

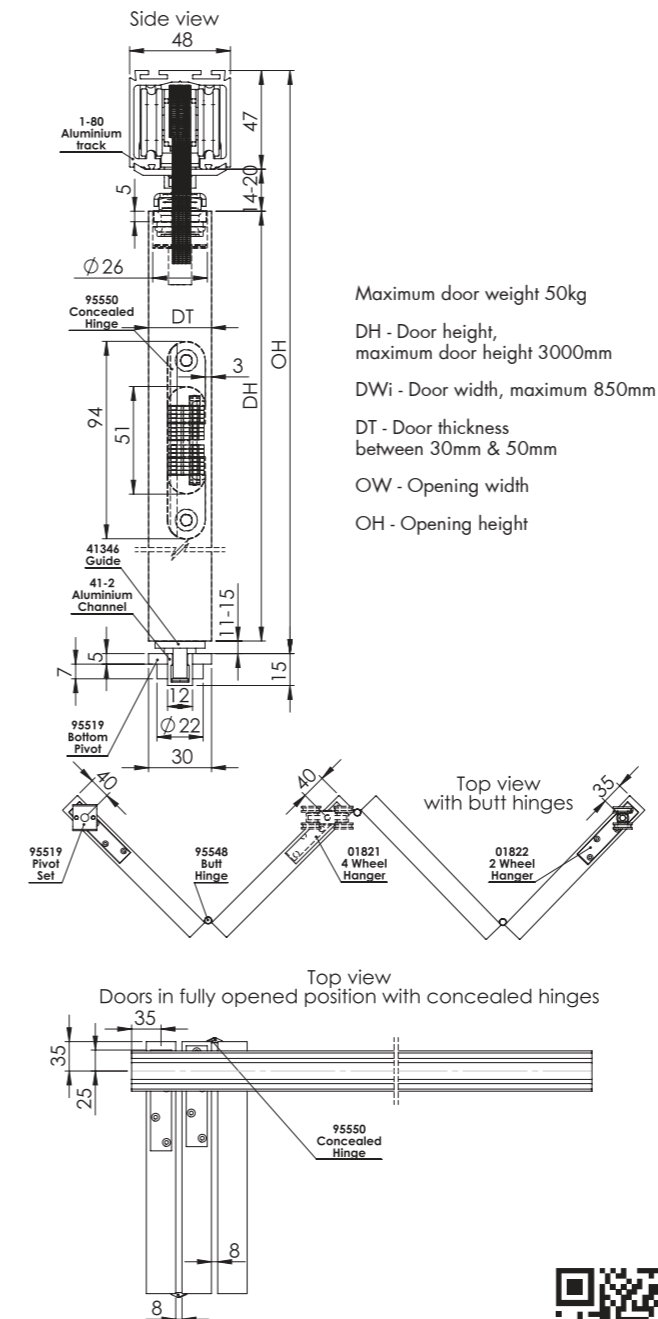

Sliding & Folding Door Systems



For further information please contact us:  
Tel: +44 (0)20 8545 6680 sales@coburn.co.uk www.coburn.co.uk

| Article No. | Finish/Size   | Track          |
|-------------|---|----------------|
| 18020       | Anodised Aluminium, 2000mm                              |                |
| 18030       | Anodised Aluminium, 3000mm                              |                |
| 18040       | Anodised Aluminium, 4000mm                              |                |
| 18060       | Anodised Aluminium, 6000mm                              |                |
| Article No. | Description   | Image          |
| 95519       | Top & bottom pivot assembly, zinc plated                |                |
| 01822       | 2 wheel end hanger set, zinc plated                     |                |
| 01821       | 4 wheel intermediate hanger, zinc plated                |                |
| 95548       | 3 hinge set, satin stainless steel                      |                |
| 95550       | Concealed Soss hinge (pack of 3)                        |                |
| 41346       | Bottom folding door guide                               |                |
| Article No. | Finish/Size   | Bottom Channel |
| 41224       | Mill Finish, 12x15mm, 2400mm                            |                |
| 41236       | Mill Finish, 12x15mm, 3600mm                            |                |
| 41260       | Mill Finish, 12x15mm, 6000mm                            |                |
| Accessories |   |                |
| 95690       | Flush bolt – Brass finish, 200mm                        |                |
| 95697       | Flush bolt – Silver finish, 200mm                       |                |
| 95698       | Flush bolt – Black finish, 200mm                        |                |
| 95662       | Holdback Catch – Black finish                           |                |
| 95663       | Holdback Catch – Silver finish                          |                |
| 95664       | Holdback Catch – Brass finish                           |                |
| 95680       | Round Flush pull - Satin Silver Finish 58 x 11mm        |                |
| 95681       | Round Flush pull - Satin Brass Finish 58 x 11mm         |                |
| 95630       | Rectangular Flush pull handle 180 x 45mm - Black Finish |                |





Foldaside 75 Sliding & Folding Door Systems

### Door Specifications

- Maximum Door Weight: 75kg
- Door Thickness: 35-50mm
- Maximum Door Height: 3000mm
- Maximum Door Width: 950mm
- Track Dimensions: 51mm (w) x 55mm (h)

### Hardware Specifications

- Up to 6 panels folding in one direction
- No visible bottom door guide or unsightly floor channels for 2 door configurations
- 3D concealed hinges (silver finish) allow vertical, horizontal and depth adjustment for perfect alignment
- Stainless steel butt hinges are also available as an alternative to concealed hinges
- Hardware components are not handed and are suitable for both inward or outward opening applications
- Closed panels are held in place by flushbolts, a choice of style and length to suit customers requirements



## Foldaside 75 Folding Door Systems

### Product Overview

Foldaside 75 is a high quality door system designed for heavy duty wooden folding walls or doors up to 75kgs per leaf and is ideal for partitioning off rooms in either residential or commercial applications. A robust pivot bearing is used to secure the end door within the set and the other panels are aligned by unobtrusive 3D adjustable concealed hinges, which can allow vertical, horizontal and depth adjustment after installation, to ensure a perfect fit.

#### NOTE:

- All accessories to be ordered separately
- For more detailed information please refer to our Technical Data Sheet available on request

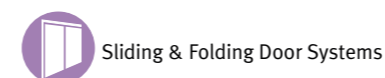
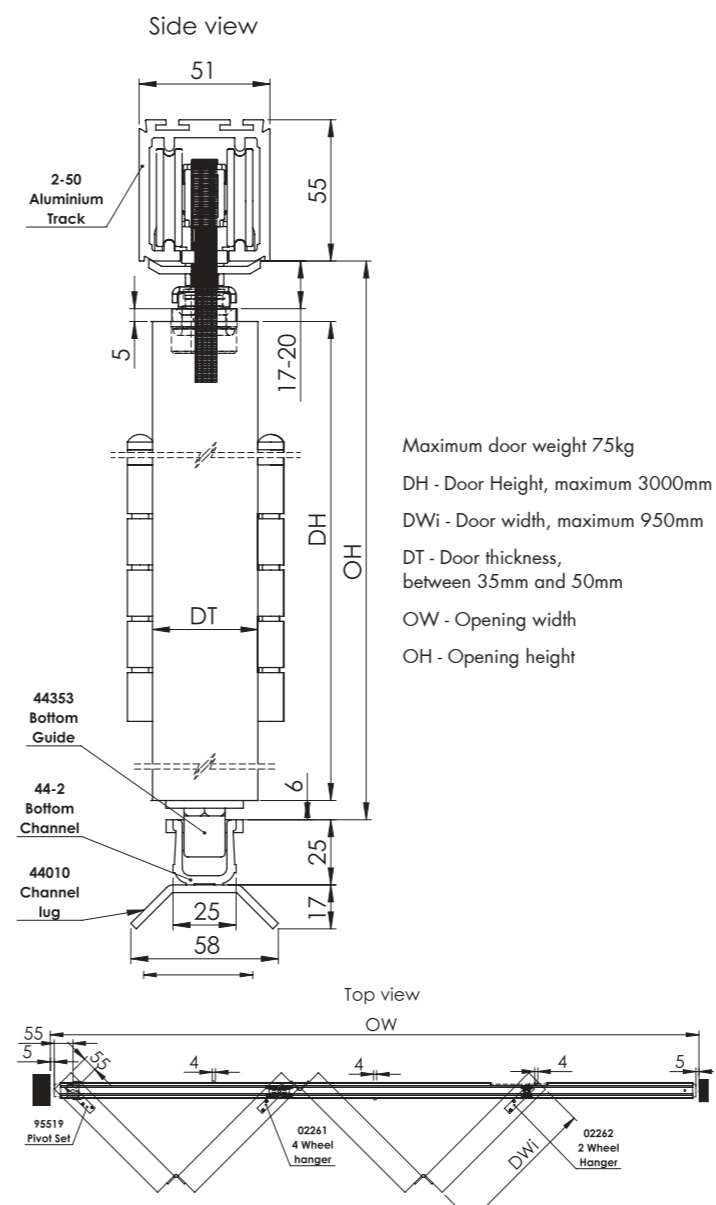

For further information please contact us:  
 Tel: +44 (0)20 8545 6680 sales@coburn.co.uk www.coburn.co.uk

| Article No. | Finish/Size   | Track          |
|-------------|---|----------------|
| 25024       | Anodised Aluminium, 2400mm                              |                |
| 25030       | Anodised Aluminium, 3000mm                              |                |
| 25036       | Anodised Aluminium, 3600mm                              |                |
| 25040       | Anodised Aluminium, 4000mm                              |                |
| 25060       | Anodised Aluminium, 6000mm                              |                |
| Article No. | Description   | Image          |
| 02261       | 4Wheel intermediate hanger                              |                |
| 02262       | 2 Wheel end hanger                                      |                |
| 44353       | Nylon roller guide for timber door                      |                |
| 95519       | Top and bottom pivot set                                |                |
| 95549       | Satin Stainless Steel Butt hinge (pack of 3)            |                |
| 95554       | 3D adjustable concealed hinge (pack of 2)               |                |
| Article No. | Finish/Size   | Bottom Channel |
| 44224       | Mill Finish, 25x25mm, 2400mm                            |                |
| 44236       | Mill Finish, 25x25mm, 3600mm                            |                |
| 44260       | Mill Finish, 25x25mm, 6000mm                            |                |
| Accessories |   |                |
| 95690       | Flush bolt – Brass finish, 200mm                        |                |
| 95697       | Flush bolt – Silver finish, 200mm                       |                |
| 95698       | Flush bolt – Black finish, 200mm                        |                |
| 95662       | Holdback Catch – Black finish                           |                |
| 95663       | Holdback Catch – Silver finish                          |                |
| 95664       | Holdback Catch – Brass finish                           |                |
| 95680       | Round Flush pull - Satin Silver Finish 58 x 11mm        |                |
| 95681       | Round Flush pull - Satin Brass Finish 58 x 11mm         |                |
| 95630       | Rectangular Flush pull handle 180 x 45mm - Black Finish |                |



Foldaside 150 Sliding & Folding Door Systems

### Door Specifications

- Maximum Door Weight: 150kg
- Door Thickness: 42-65mm
- Maximum Door Height: 4500mm
- Maximum Door Width: 1500mm
- Track Dimensions: 70mm (w) x 78mm (h)

### Hardware Specifications

- Up to 8 panels folding in one direction.
- 3D concealed hinges (silver finish) allow vertical, horizontal and depth adjustment for perfect alignment.
- Closed panels are held in place by flushbolts, with a choice of style and length to suit customer's requirements.
- Hardware components are non handed and are suitable for both inward or outward opening applications.



# Foldaside 150

## Folding Door Systems

### Product Overview

Foldaside 150 is a sophisticated high quality hardware system designed for internal or external folding doors up to 150 kg per leaf.

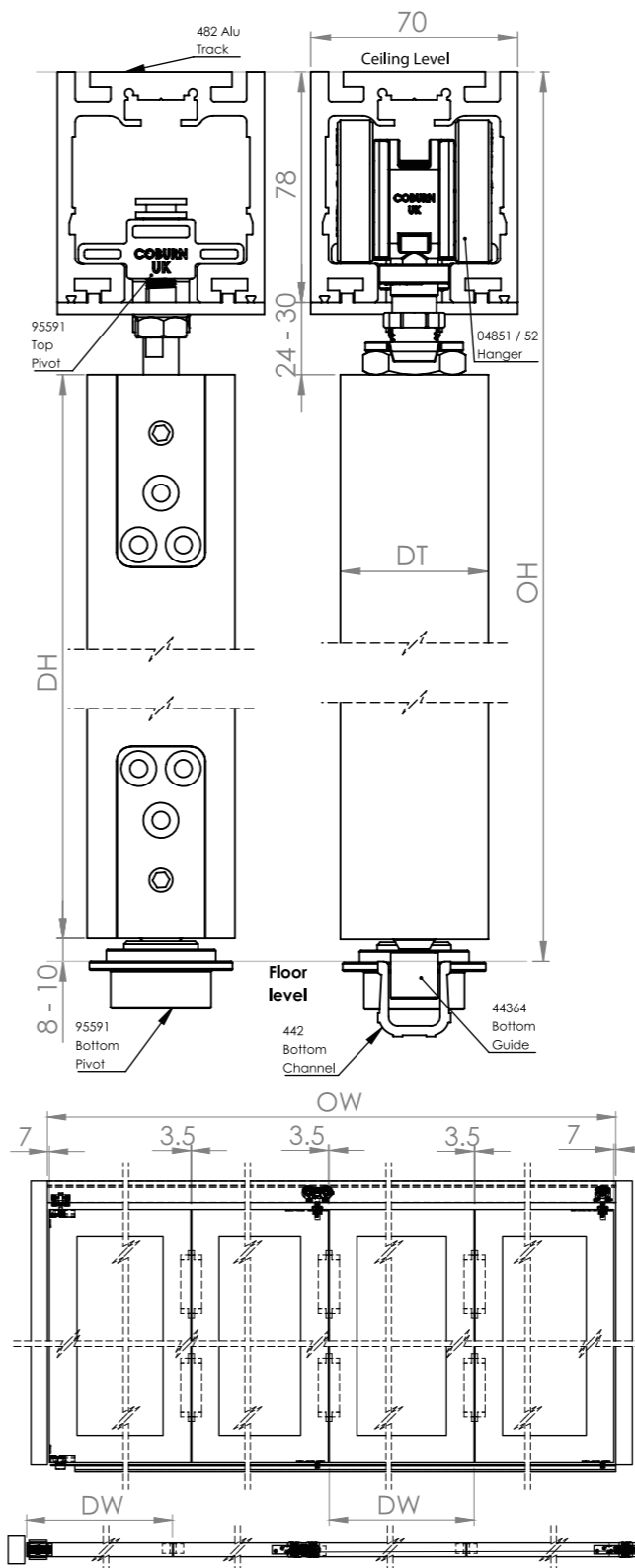

| Article No. | Finish/Size   | Track          |
|-------------|---|----------------|
| 48230       | Anodized Aluminium Track 3000mm                             |                |
| 48260       | Anodized Aluminium Track 6000mm                             |                |
| Article No. | Description   | Image          |
| 04851       | 2 Wheel Hanger  |                |
| 04852       | 4 Wheel Hanger  |                |
| 44364       | Bottom Guide  |                |
| 95591       | Top & Bottom Pivot Set                                      |                |
| 95555       | 3D Adjustable concealed Hinge (Silver Finish)               |                |
| Article No. | Finish/Size   | Bottom Channel |
| 44230       | Mill Finish Aluminium Channel 3000mm                        |                |
| 44260       | Mill Finish Aluminium Channel 6000mm                        |                |
| Accessories |   |                |
| 95663       | Hold Back Catch Silver                                      |                |
| 95612       | Rectangular Flush Handle-Stainless Steel Finish 100x50x19mm |                |
| 95625       | Round Flush Handle Stainless Steel 90x21mm with screw holes |                |
| 95626       | Round Flush Handle Stainless Steel 90x21mm                  |                |
| 95628       | Rectangular Flush Handle-Stainless Steel Finish 180x45mm    |                |
| 95629       | Rectangular Flush Handle-Stainless Steel Finish 180x60mm    |                |
| 09841       | Flushbolt, non-lockable, satin stainless steel, 400mm       |                |
| 09843       | Flushbolt, non-lockable, satin stainless steel, 200mm       |                |

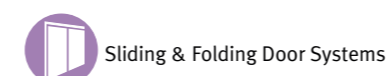





Manufactured with greater corrosion resistant levels for sliding & folding doors, which are to be installed in locations, subjected to adverse weather conditions.

# External Door Systems







Dreamfold External Door Systems

# Dreamfold

## External Door Systems

### Product Overview

Dreamfold is a highly durable hardware system meticulously designed for external timber folding doors, where a high level of corrosion resistance and weather proofing is required. The system operates with effortless ease enabling the folding doors to fully open either outwards or inwards to allow the user to enjoy the great outdoors.

#### NOTE:

- All accessories to be ordered separately
- For more detailed information please refer to our Technical Data Sheet available on request

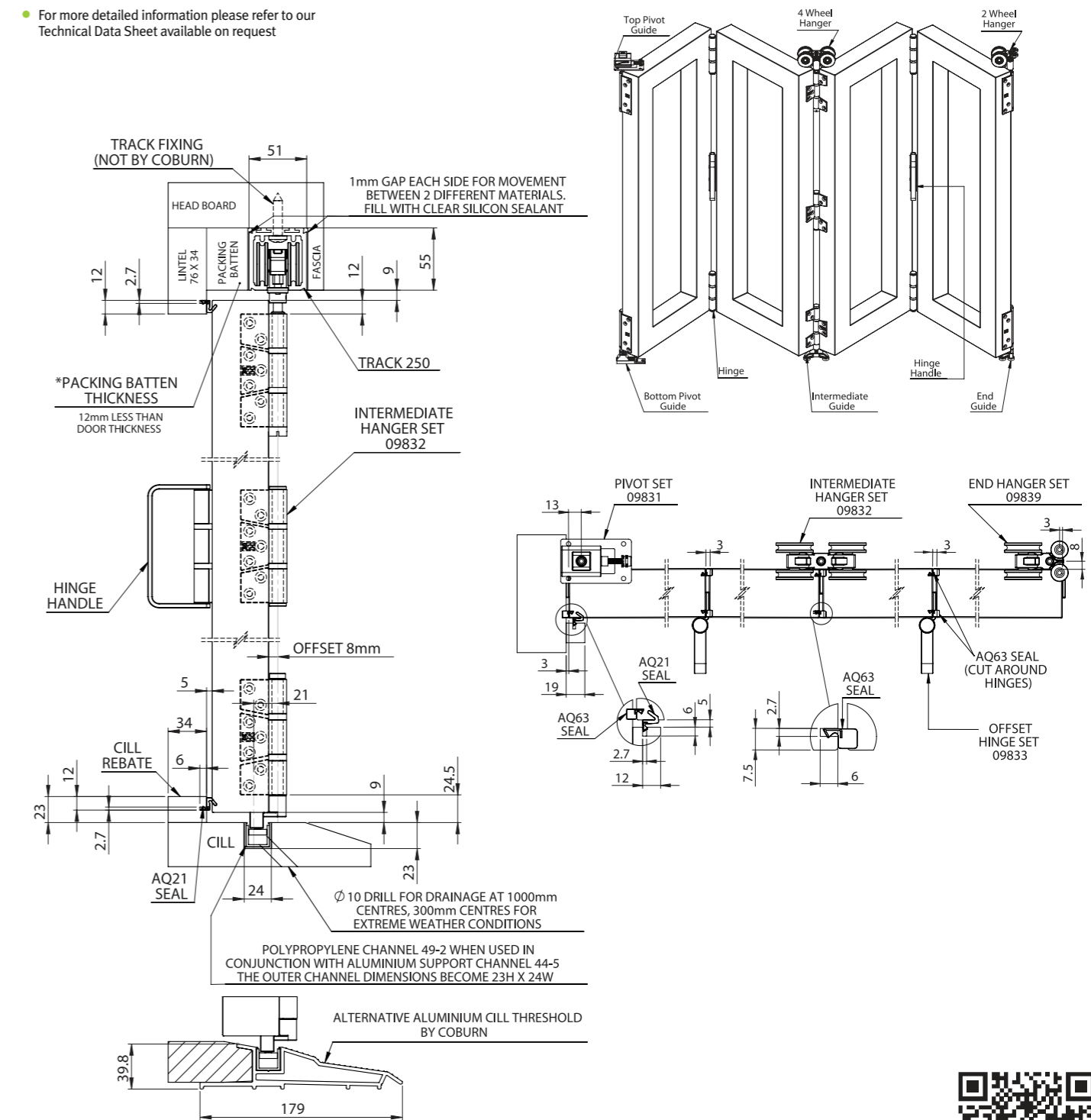

### Door Specifications

- Maximum Door Weight: 85kgs
- Door Thickness: 35-70mm
- Maximum Door Height: 3300mm
- Track Dimensions: 51mm (w) x 55mm (h)

### Hardware Specifications

- Cast grade 304 stainless steel hangers c/w delrin nylon outer wheels and precision stainless steel bearings
- Precision made components guarantee smooth and silent operation
- Door and frame seals provide superior weatherproofing
- Salt spray tested for 240 hours. Equivalent to BS EN 1670:2007 Grade 4 (high corrosion resistance)
- Suitable for up to 8 door leaves in a single direction
- Variable height and sideways adjustment in doors
- Aluminium threshold and other accessories available

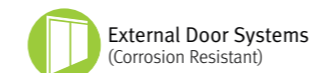



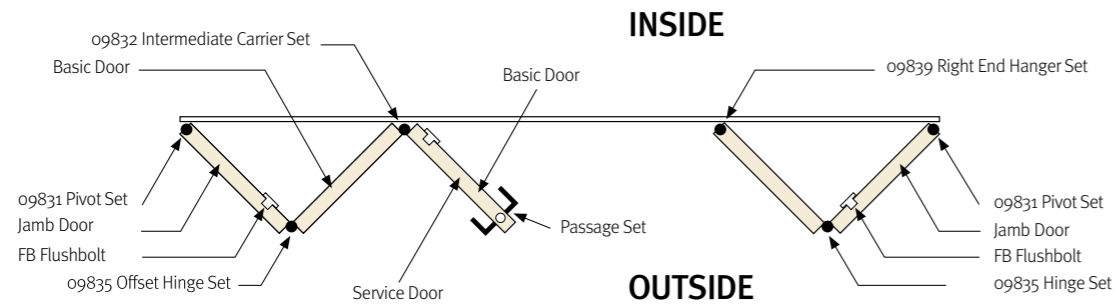

Common Panel Layouts for Outward Opening Doors

| Hardware Legend |                            |
|-----------------|----------------------------|
| 09831           | Pivot set                  |
| 09832           | Intermediate carrier set   |
| 09834           | Left carrier set           |
| 09839           | Right carrier set          |
| 09835           | Outward offset hinge set   |
| 09833           | Outward straight hinge set |
| FB              | Flushbolt                  |

Outward Application Option

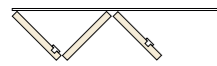

| Article No. | Outward Opening Configurations |
|-------------|--------------------------------|
| 09869       | 2 LEAF                         |
| 09871       | 2+1 LEAF                       |
| 09861       | 3 LEAF                         |
| 09873       | 2+2 LEAF                       |
| 09875       | 3+1 LEAF                       |
| 09863       | 4 LEAF                         |
| 09877       | 3+2 LEAF                       |
| 09879       | 4+1 LEAF                       |
| 09865       | 5 LEAF                         |
| 09881       | 3+3 LEAF                       |
| 09883       | 4+2 LEAF                       |
| 09885       | 5+1 LEAF                       |
| 09867       | 6 LEAF                         |

Common Panel Layouts for Inward Opening Doors

| Hardware Legend |                           |
|-----------------|---------------------------|
| 09831           | Pivot set                 |
| 09832           | Intermediate carrier set  |
| 09834           | Left carrier set          |
| 09839           | Right carrier set         |
| 09837           | Inward offset hinge set   |
| 09840           | Inward straight hinge set |
| FB              | Flushbolt                 |

Inward Application Option

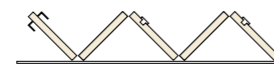

| Article No. | Inward Opening Configurations |
|-------------|-------------------------------|
| 09870       | 2 LEAF                        |
| 09872       | 2+1 LEAF                      |
| 09862       | 3 LEAF                        |
| 09874       | 2+2 LEAF                      |
| 09876       | 3+1 LEAF                      |
| 09864       | 4 LEAF                        |
| 09878       | 3+2 LEAF                      |
| 09880       | 4+1 LEAF                      |
| 09866       | 5 LEAF                        |
| 09882       | 3+3 LEAF                      |
| 09884       | 4+2 LEAF                      |
| 09886       | 5+1 LEAF                      |
| 09868       | 6 LEAF                        |

# Dreamfold

## External Door Systems

| Article No. | Finish/Size  | Track |
|-------------|--|-------|
| 25024       | Anodised Aluminium, 2400mm   |       |
| 25030       | Anodised Aluminium, 3000mm   |       |
| 25036       | Anodised Aluminium, 3600mm   |       |
| 25040       | Anodised Aluminium, 4000mm   |       |
| 25060       | Anodised Aluminium, 6000mm   |       |
| Article No. | Description  | Image |
| 09831       | Top & bottom pivot assembly, satin stainless steel                       |       |
| 09834       | 2 wheel end hanger set, left hand, satin stainless steel                 |       |
| 09839       | 2 wheel end hanger set, right hand, satin stainless steel                |       |
| 09832       | 4 wheel intermediate hanger & guide set, satin stainless steel           |       |
| 09833       | 3 hinge set c/w handle, outward opening, satin stainless steel           |       |
| 09835       | 3 hinge set c/w handle (off-set), outward opening, satin stainless steel |       |
| 09837       | 3 hinge set (off-set), inward opening, satin stainless steel             |       |
| 09840       | 3 hinge set, inward opening, satin stainless steel                       |       |
| 09836       | Intermediate pivot hinge, satin stainless steel                          |       |
| 09843       | Flushbolt, non-lockable, satin stainless steel, 200mm                    |       |
| 09841       | Flushbolt, non-lockable, satin stainless steel, 400mm                    |       |

| Article No. | Finish/Size  | Support Channel       |
|-------------|--|-----------------------|
| 44520       | Mill Finish, 24x23mm, 2000mm                               |                       |
| 44530       | Mill Finish, 24x23mm, 3000mm                               |                       |
| 44540       | Mill Finish, 24x23mm, 4000mm                               |                       |
| 44560       | Mill Finish, 24x23mm, 6000mm                               |                       |
| Article No. | Finish/Size  | Threshold             |
| 49324       | Silver Anodised, 180 x 40mm, 2400mm                        |                       |
| 49336       | Silver Anodised, 180 x 40mm, 3600mm                        |                       |
| 49360       | Silver Anodised, 180 x 40mm, 6000mm (Outward opening only) |                       |
| Article No. | Finish/Size  | Polypropylene Channel |
| 49220       | Black, 2000mm  |                       |
| 49230       | Black, 3000mm  |                       |
| 49240       | Black, 4000mm  |                       |
| 49260       | Black, 6000mm  |                       |
| Article No. | Description  | Seal                  |
| 07211       | Door perimeter seal, brown (per door)                      |                       |
| 07212       | Frame perimeter seal, brown (per lm)                       |                       |

**NOTE:**

- All accessories to be ordered separately
- For more detailed information please refer to our Technical Data Sheet available on request

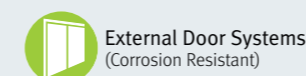



Eternal 130 External Door Systems

### Door Specifications

- Maximum Door Weight: 130kgs
- Door Thickness: 20-50mm
- Maximum Door Height: 3000mm
- Track Dimensions: 38mm (w) x 41mm (h)

### Hardware Specifications

- Tracks can be ceiling mounted or face fitted
- Suitable for timber, aluminium or metal doors
- Cast SS316 stainless steel hangers c/w delrin nylon outer wheels and precision stainless steel bearings ensure optimum corrosion resistance
- No recessed floor tracks necessary for timber doors
- Salt spray tested for 500 hours. Exceeds BS EN 1670:2007 Grade 5. Exceptionally high corrosion resistance. (Suitable for extreme conditions where long term protection is needed)
- Soft closing available for doors 680mm wide and over.
- Soft closing and opening with single damper available for doors 1020mm wide and over.
- Soft closing and opening with double damper available for doors 615mm wide and over.

# Eternal 130

## External Door Systems

### Product Overview

Eternal 130 top hung sliding door system is manufactured using cutting edge technology, which has been developed to maximise longevity of the sliding door system. The system is also available with soft closing and low headroom opening features. The system is ideal for external sliding doors which are to be installed in locations where the severest weather conditions are prevalent and where doors are exposed to high levels of corrosion.

#### NOTE:

- All accessories to be ordered separately
- For more detailed information please refer to our Technical Data Sheet available on request

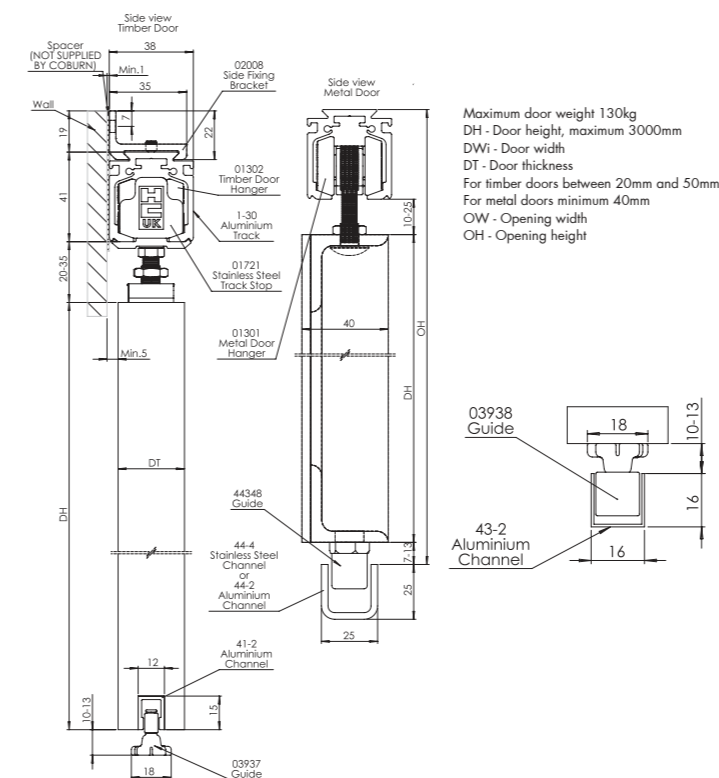

| Article No. | Finish/Size                  | Bottom Channel |
|-------------|------------------------------|----------------|
| 41224       | Mill Finish, 12x15mm, 2400mm |                |
| 41236       | Mill Finish, 12x15mm, 3600mm |                |
| 41260       | Mill Finish, 12x15mm, 6000mm |                |
| 43220       | Mill Finish, 15x15mm, 2000mm |                |
| 43224       | Mill Finish, 15x15mm, 2400mm |                |
| 43230       | Mill Finish, 15x15mm, 3000mm |                |
| 43236       | Mill Finish, 15x15mm, 3600mm |                |
| 43240       | Mill Finish, 15x15mm, 4000mm |                |
| 43260       | Mill Finish, 15x15mm, 6000mm |                |
| 44224       | Mill Finish, 25x25mm, 2400mm |                |
| 44236       | Mill Finish, 25x25mm, 3600mm |                |
| 44260       | Mill Finish, 25x25mm, 6000mm |                |

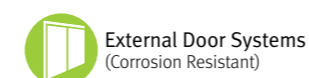

For further information please contact us:  
Tel: +44 (0)20 8545 6680 sales@coburn.co.uk www.coburn.co.uk

| Article No. | Finish/Size                | Track |
|-------------|----------------------------|-------|
| 13020       | Anodised Aluminium, 2000mm |       |
| 13024       | Anodised Aluminium, 2400mm |       |
| 13030       | Anodised Aluminium, 3000mm |       |
| 13036       | Anodised Aluminium, 3600mm |       |
| 13040       | Anodised Aluminium, 4000mm |       |
| 13060       | Anodised Aluminium, 6000mm |       |

| Article No. | Description  | Image |
|-------------|--|-------|
| 01301       | 130 hanger for metal doors, stainless steel (pair)                             |       |
| 01302       | 130 hanger with concealed apron plate for timber doors, stainless steel (pair) |       |
| 03937       | Adjustable rattle proof guide - 6mm roller                                     |       |
| 03938       | Adjustable rattle proof guide - 13mm roller                                    |       |
| 44319       | Floor guide, pair, (metal doors)   |       |
| 02008       | Face fixed bracket set (5 pcs)   |       |
| 02009       | Face fixed bracket set (8 pcs)   |       |
| 02010       | Joining bracket  |       |
| 01721       | Track stop, pair, stainless steel  |       |
| 30632       | Soft closer, single damper, 130kgs (mounted in track)                          |       |
| 30662       | Soft closer, double damper, 130kgs (mounted in track)                          |       |
| 97741       | Microline  |       |







# Eternal 180

## External Door Systems

### Product Overview

Eternal 180 top hung sliding door system is manufactured using cutting edge technology, which has been developed to maximise longevity of the sliding door system. The system is ideal for external sliding doors which are to be installed in locations where the severest weather conditions are prevalent and where doors are exposed to high levels of corrosion.

#### NOTE:

- All accessories to be ordered separately
- For more detailed information please refer to our Technical Data Sheet available on request

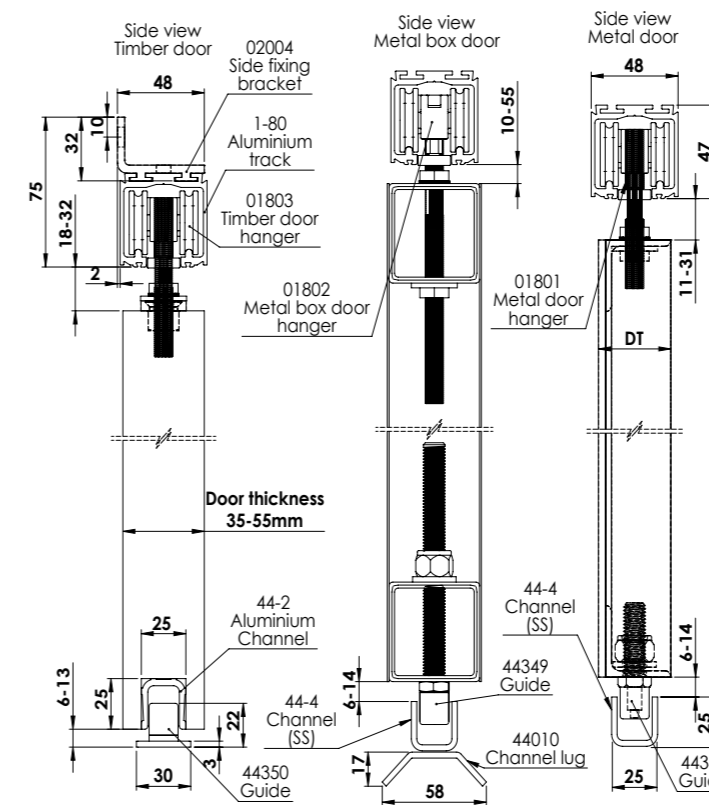

### Eternal 180 External Door Systems

#### Door Specifications

- Maximum Door Weight: 180kgs
- Door Thickness: 25-55mm
- Maximum Door Height: 3500mm
- Track Dimensions: 48mm (w) x 47mm (h)
- Track Dimensions for 25-9 Track (Soft Closer) 53mm (w) x 64mm (h)

#### Hardware Specifications

- Tracks can be ceiling mounted or face fitted.
- Suitable for timber, aluminium or metal doors.
- Cast SS316 stainless steel hangers c/w delrin nylon outer wheels and precision stainless steel bearings ensure optimum corrosion resistance.
- No recessed floor tracks required for timber doors.
- Salt spray tested for 500 hours. Exceeds BS EN 1670:2007 Grade 5 Exceptionally high corrosion resistance. (Suitable for extreme conditions where long term protection is needed)
- Soft closing available for doors 800mm wide and over.
- Soft closing and soft opening available for doors 1230mm wide and over.

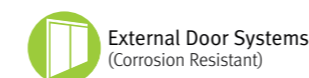

For further information please contact us:  
Tel: +44 (0)20 8545 6680 sales@coburn.co.uk www.coburn.co.uk



| Article No. | Finish/Size   | Track          |
|-------------|---|----------------|
| 18024       | Anodised Aluminium, 2400mm  |                |
| 18030       | Anodised Aluminium, 3000mm  |                |
| 18036       | Anodised Aluminium, 3600mm  |                |
| 18040       | Anodised Aluminium, 4000mm  |                |
| 18060       | Anodised Aluminium, 6000mm  |                |
| 25924       | Anodised Aluminium, 2400mm  |                |
| 25930       | Anodised Aluminium, 3000mm  |                |
| 25936       | Anodised Aluminium, 3600mm  |                |
| 25960       | Anodised Aluminium, 6000mm  |                |
| Article No. | Description   | Image          |
| 01801       | 180 hanger for metal doors, stainless steel (pair)                      |                |
| 01802       | 180 hanger for box frame metal doors, stainless steel (pair)            |                |
| 01803       | 180 hanger with concealed apron plate for timber doors, st/steel (pair) |                |
| 44348       | Floor guide, stainless steel (metal doors)                              |                |
| 44349       | Extended floor guide, stainless steel (metal box frame doors)           |                |
| 44350       | Concealed floor guide, stainless steel (timber doors)                   |                |
| 02005       | Face fixed bracket set (5 pcs)  |                |
| 02006       | Face fixed bracket set (8 pcs)  |                |
| 30638       | Soft closer 180kg (Concealed in track)                                  |                |
| 02719       | Track stop, pair, stainless steel                                       |                |
| 97741       | Microline   |                |
| Article No. | Finish/Size   | Bottom Channel |
| 44224       | Mill Finish, 25x25mm, 2400mm  |                |
| 44236       | Mill Finish, 25x25mm, 3600mm  |                |
| 44260       | Mill Finish, 25x25mm, 6000mm  |                |
| 44421       | Satin stainless steel, 25x25mm, 2100mm                                  |                |
| 44430       | Satin stainless steel, 25x25mm, 3000mm                                  |                |





Eternal 250 External Door Systems

# Eternal 250

## External Door Systems

### Product Overview

Eternal 250 top hung sliding door system is manufactured using cutting edge technology, which has been developed to maximise longevity of the sliding door system. The system is ideal for heavy duty external sliding doors which are to be installed in locations where the severest weather conditions are prevalent and where doors are exposed to high levels of corrosion.

#### NOTE:

- All accessories to be ordered separately
- For more detailed information please refer to our Technical Data Sheet available on request

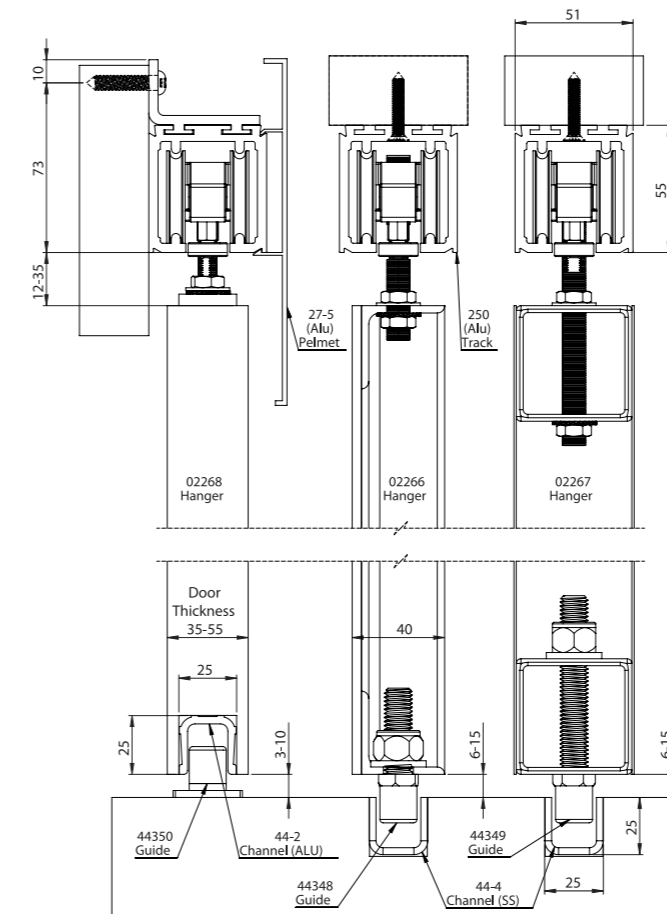

### Door Specifications

- Maximum door weight: 250kg
- Door Thickness: 25 – 55mm
- Maximum door height: 4000mm
- Track Dimensions: 51mm (w) x 55mm (h)
- Track Dimensions for 25-9 track (Soft Closer) 53mm (w) x 64mm (h)

### Hardware Specifications

- Tracks can be ceiling mounted or face fixed.
- Suitable for timber, aluminium or metal doors.
- Cast SS316 stainless steel hangers c/w delrin nylon outer wheels and precision stainless steel bearings ensure optimum corrosion resistance.
- No recessed floor tracks necessary for timber doors.

- Salt spray tested for 500 hours. Exceeds BS EN 1670:2007 Grade 5. Exceptionally high corrosion resistance. (Suitable for extreme conditions where long term protection is needed)
- Soft closing available for doors 810mm wide and over.
- Soft closing and soft opening available for doors 1240mm

| Article No. | Finish/Size                      | Fascia Pelmet |
|-------------|----------------------------------|---------------|
| 27501       | End caps for 27-5 Pelmet         |               |
| 27524       | Anodised Aluminium Pelmet 2400mm |               |
| 27530       | Anodised Aluminium Pelmet 3000mm |               |
| 27536       | Anodised Aluminium Pelmet 3600mm |               |
| 27560       | Anodised Aluminium Pelmet 6000mm |               |

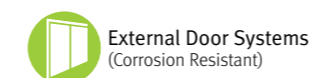

For further information please contact us:  
Tel: +44 (0)20 8545 6680 sales@coburn.co.uk www.coburn.co.uk

| Article No. | Finish/Size   | Track          |
|-------------|---|----------------|
| 25024       | Anodised Aluminium, 2400mm  |                |
| 25030       | Anodised Aluminium, 3000mm  |                |
| 25036       | Anodised Aluminium, 3600mm  |                |
| 25040       | Anodised Aluminium, 4000mm  |                |
| 25060       | Anodised Aluminium, 6000mm  |                |
| Article No. | Description   | Image          |
| 02266       | 250 hanger for metal doors, stainless steel (pair)                      |                |
| 02267       | 250 hanger for box frame metal doors, stainless steel (pair)            |                |
| 02268       | 250 hanger with concealed apron plate for timber doors, st/steel (pair) |                |
| 44348       | Floor guide, stainless steel (metal doors)                              |                |
| 44349       | Extended floor guide, stainless steel (metal box frame doors)           |                |
| 44350       | Concealed floor guide, stainless steel (timber doors)                   |                |
| 02005       | Face fixed bracket set (5 pcs)  |                |
| 02006       | Face fixed bracket set (8 pcs)  |                |
| 30641       | Soft closer 250kg (Concealed in track)                                  |                |
| 02719       | Track stop, pair, stainless steel                                       |                |
| 97741       | Microline   |                |
| Article No. | Finish/Size   | Bottom Channel |
| 44224       | Mill Finish, 25x25mm, 2400mm  |                |
| 44236       | Mill Finish, 25x25mm, 3600mm  |                |
| 44260       | Mill Finish, 25x25mm, 6000mm  |                |
| 44421       | Satin stainless steel, 25x25mm, 2100mm                                  |                |
| 44430       | Satin stainless steel, 25x25mm, 3000mm                                  |                |





Designed to be stylish and sleek, these contemporary glass sliding, folding & stacking door systems create a minimalistic and sophisticated look, suitable for both residential and commercial applications.

# Glass Door Systems





Slyde 15 Glass - Glass Door System

### Door Specification

- Maximum weight for a single door: 15kg
- Glass door thickness: 5mm
- Single door size width: 500-1200mm

### Hardware Specification

- Nylon wheels for silent performance and durability.
- Integrated soft closing and opening as standard.

## Slyde 15 Glass Glass Door Systems

### Product Overview

Slyde 15 system provides a highly functional solution for bookcases, display units and cabinet doors. Equipped with single or double concealed top tracks that can be accurately cut to the desired length, which ensures a professional and streamlined appearance. This systems also offers component packs for both timber and glass doors, which include soft close dampers as standard, ensuring a smooth and quiet door closure everytime. Slyde 15 is a versatile and straight forward option for sliding cabinet doors that requires minimal installation effort.

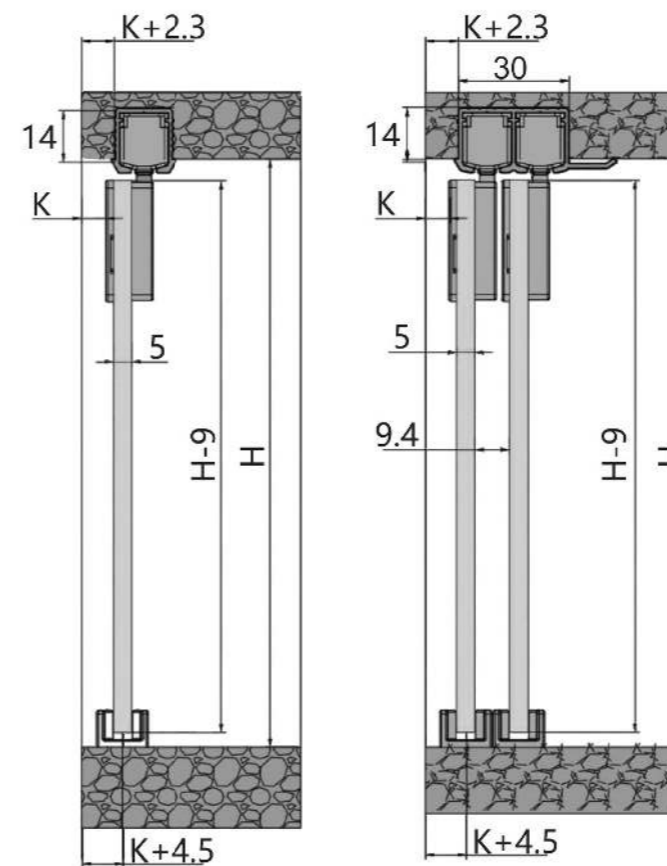

Top Track (Single door)

Top Track (Double door)

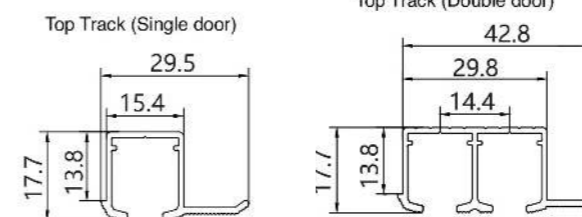

Top Track (Single door)

Top Track (Double door)

### NOTE:

- All accessories to be ordered separately
- For more detailed information please refer to our Technical Data Sheet available on request



Glass Door Systems



For further information please contact us:

Tel: +44 (0)20 8545 6680 sales@coburn.co.uk www.coburn.co.uk

| Article No. | Finish/Size  | Single Track                |
|-------------|--|-----------------------------|
| 81110       | Slyde 15 (1m) Single Track for Timber & Glass, Silver anodised |                             |
| 81120       | Slyde 15 (2m) Single Track for Timber & Glass, Silver anodised |                             |
| 81130       | Slyde 15 (3m) Single Track for Timber & Glass, Silver anodised |                             |
| Article No. | Finish/Size  | Double Glass Set Track      |
| 81410       | Slyde 15 (1m) Double Track for Glass, Silver anodised          |                             |
| 81420       | Slyde 15 (2m) Double Track for Glass, Silver anodised          |                             |
| 81430       | Slyde 15 (3m) Double Track for Glass, Silver anodised          |                             |
| Article No. | Finish/Size  | 1 Door Components Set Glass |
| 81106       | Slyde 15 1 Door Component Set (Glass)                          |                             |





**Straightaway G80 Glass Door Systems**

# Straightaway G80 Glass Door Systems

## Product Overview

Straightaway G80 is a simple but discrete straight sliding system ideal for lightweight interior frameless glass doors, where no cut-outs are required in the glass.

A compact top track, which can be ceiling mounted, recessed within a ceiling void or fitted directly to a face of a wall, combined with an inconspicuous guide at floor level, help create a minimalistic and sophisticated look.

### NOTE:

- All accessories to be ordered separately
- For more detailed information please refer to our Technical Data Sheet available on request

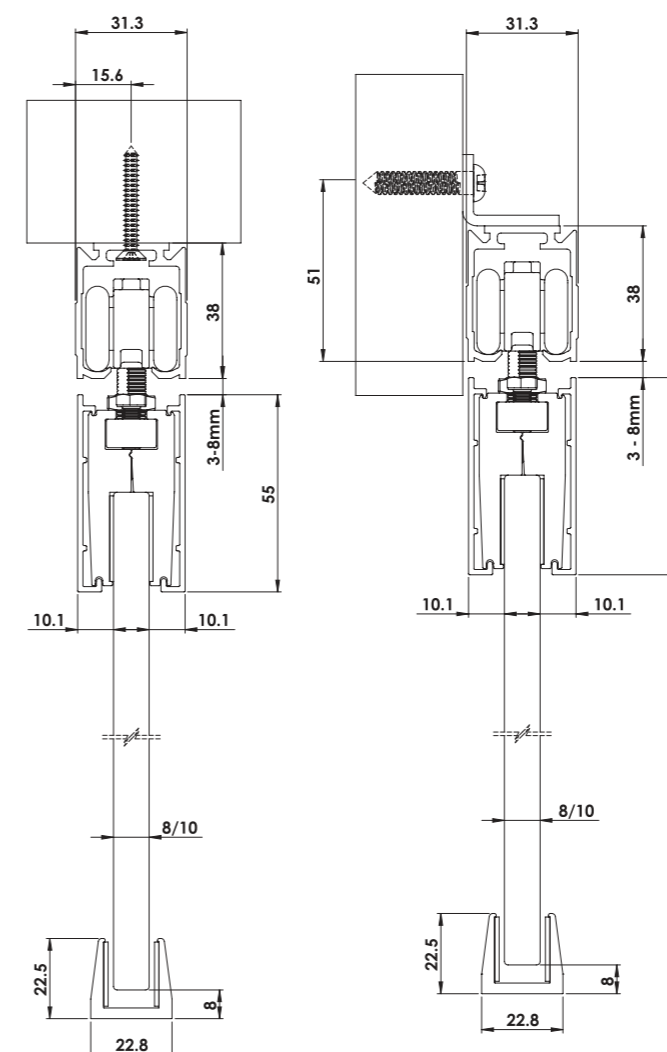

For further information please contact us:  
Tel: +44 (0)20 8545 6680 sales@coburn.co.uk www.coburn.co.uk



| Article No. | Finish/Size  | Track |
|-------------|--|-------|
| 12320       | Anodised Aluminium, 2000mm                                 |       |
| 12324       | Anodised Aluminium, 2400mm                                 |       |
| 12330       | Anodised Aluminium, 3000mm                                 |       |
| 12336       | Anodised Aluminium, 3600mm                                 |       |
| 12340       | Anodised Aluminium, 4000mm                                 |       |
| 12360       | Anodised Aluminium, 6000mm                                 |       |
| Article No. | Description  | Image |
| 52103       | G80 clamp set, anodised aluminium, 80kgs (8/10mm glass)    |       |
| 52104       | G80 clamp set, satin stainless steel, 80kgs (8/10mm glass) |       |
| Article No. | Description  | Image |
| 01201       | Hanger for glass doors (pair)                              |       |
| 01725       | Track stop, pair   |       |
| 52101       | G80 clamps, anodised aluminium, 80kgs (pair)               |       |
| 52102       | G80 clamps, satin stainless steel, 80kgs (pair)            |       |
| 52201       | Glass floor guide, anodised aluminium                      |       |
| 52202       | Glass floor guide, satin stainless steel                   |       |
| 30637       | Soft closer, single damper, 100kgs (track mounted)         |       |
| 01005       | Brackets (Pack of 5)                                       |       |
| 01008       | Brackets (Pack of 8)                                       |       |
| 30664       | Soft closer, double damper, 100kgs (mounted in track)      |       |

## Door Specifications

- Maximum Door Weight: 80kg
- Glass Thickness: 8mm or 10mm
- Maximum Door Height: 2400mm
- Track Dimensions: 31mm (w) x 38mm (h)

## Hardware Specifications

- Tracks can be ceiling mounted or face fixed.
- No glass preparation required.
- Clip on cover caps available in silver anodised or brushed stainless steel finishes.
- No recessed floor tracks required.
- Soft closer available for doors 600mm wide and over.
- Soft closing and soft opening with single damper available for doors 900mm wide and over.
- Soft closing and soft opening with double damper available for doors 700mm wide and over.



# Straightaway G130 Glass Door Systems

## Product Overview

Straightaway G130 is a sleek and efficient straight sliding system suitable for heavier duty interior frameless glass doors. A compact top track, which can be ceiling mounted, recessed within a ceiling void or fitted directly to a face of a wall, combined with attractive stainless steel patch fittings and an inconspicuous guide at floor level, help create a minimalistic and sophisticated look.

### NOTE:

- All accessories to be ordered separately
- For more detailed information please refer to our Technical Data Sheet available on request

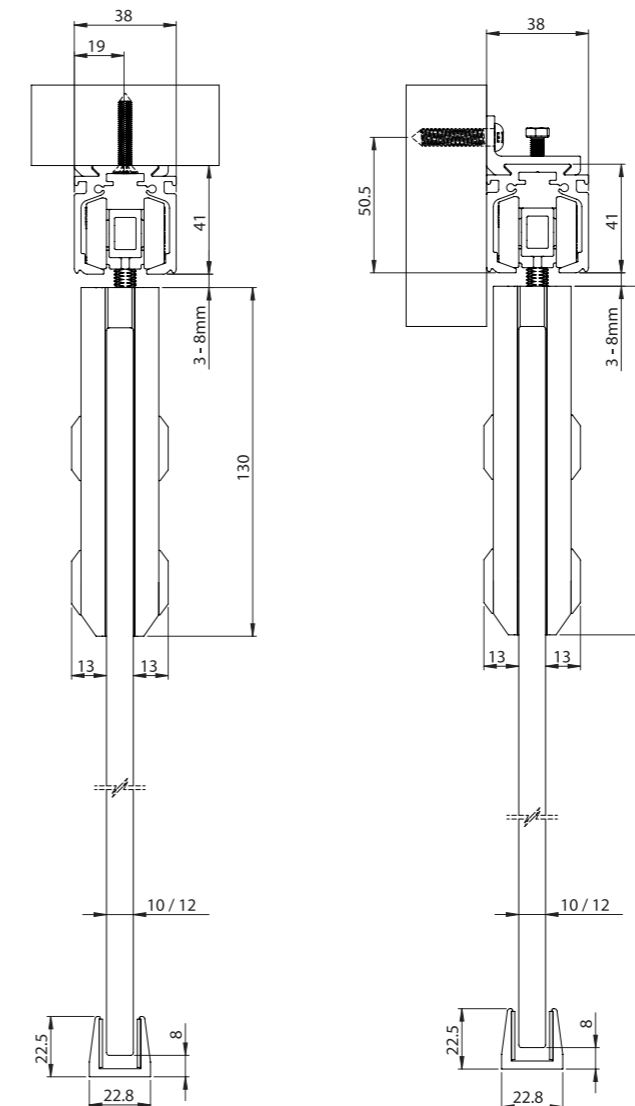

| Article No. | Finish/Size   | Track |
|-------------|---|-------|
| 13020       | Anodised Aluminium, 2000mm  |       |
| 13024       | Anodised Aluminium, 2400mm  |       |
| 13030       | Anodised Aluminium, 3000mm  |       |
| 13036       | Anodised Aluminium, 3600mm  |       |
| 13040       | Anodised Aluminium, 4000mm  |       |
| 13060       | Anodised Aluminium, 6000mm  |       |
| Article No. | Description   | Image |
| 52112       | G130 patch fitting set, satin stainless steel, 130kgs (10/12mm glass) |       |
| Article No. | Description   | Image |
| 01307       | Hanger for glass doors (pair)   |       |
| 01720       | Track stop, pair  |       |
| 52111       | G130 patch fittings, satin stainless steel, 130kgs (10/12mm glass)    |       |
| 52202       | Glass floor guide, satin stainless steel                              |       |
| 30614       | Soft closer, single damper, 130kgs (track mounted)                    |       |
| 02008       | Face fixed bracket set (5 pcs)  |       |
| 02009       | Face fixed bracket set (8 pcs)  |       |
| 02010       | Joining bracket   |       |
| 30661       | Soft closer, double damper, 130kgs (mounted in track)                 |       |

## Straightaway G130 Glass Door Systems

### Door Specifications

- Maximum Door Weight: 130kg
- Glass Thickness: 10mm or 12mm
- Maximum Door Height: 3000mm
- Track Dimensions: 38mm (w) x 41mm (h)

### Hardware Specifications

- Tracks can be ceiling mounted or face fixed
- Patch fittings supplied in brushed stainless steel finish
- No recessed floor tracks required
- Soft closer available for doors 680mm wide and over.
- Soft closing and soft opening with single damper on each end available for doors 1020mm wide and over.
- Soft closing and soft opening with double damper available for doors 615mm wide and over.



For further information please contact us:  
Tel: +44 (0)20 8545 6680 sales@coburn.co.uk www.coburn.co.uk





# Flexiglas 50 Glass Door Systems

## Product Overview

Flexiglas 50 brings a sleek and minimalistic design to any space and offers versatility and transparency to suit customers' aesthetic requirements.

The frameless glass system is suitable for lightweight interior glass doors not exceeding 50kg and can also be supplied with soft close cushioning.

### NOTE:

- All accessories to be ordered separately
- For more detailed information please refer to our Technical Data Sheet available on request

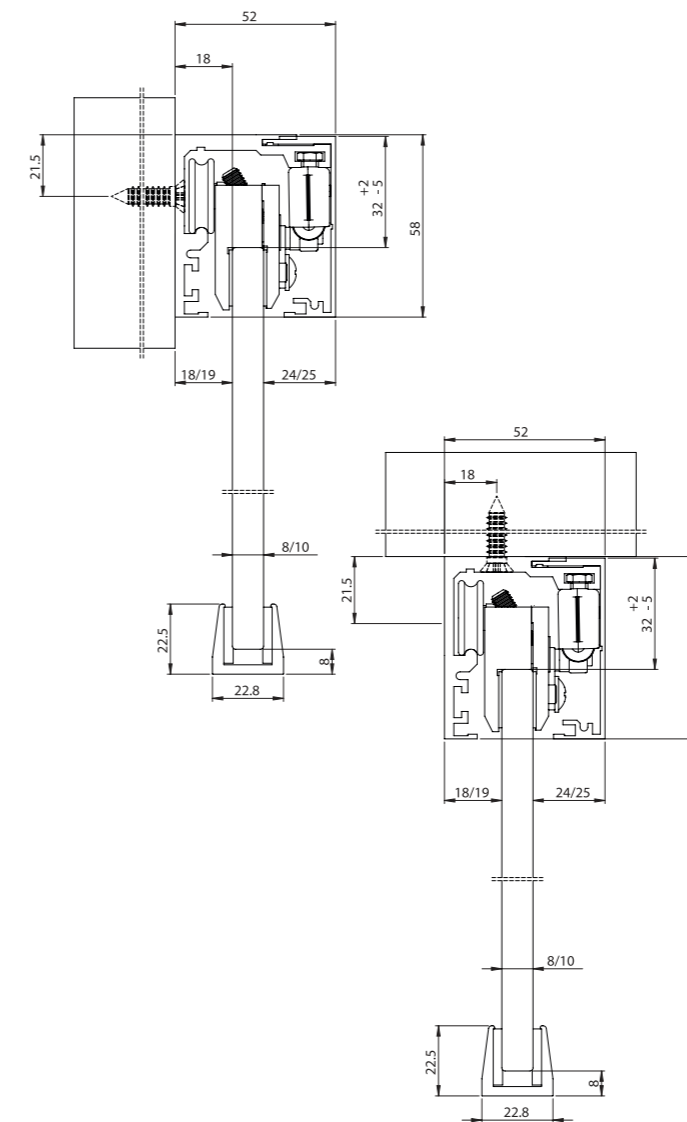

Flexiglas 50 Glass Door Systems

### Door Specifications

- Maximum Door Weight: 50kg
- Glass Thickness: 8mm - 10mm
- Maximum Door Height: 2400mm
- Track Dimensions: 52mm (w) x 58mm (h)

### Hardware Specifications

- No glass preparation required
- Soft opening/closing available as an option
- System is compatible with simultaneous opening kit (Synchro)
- No visible gaps between bottom of track and top of door
- Variable height adjustment on doors
- Additional profiles available for fixed panel mounting
- Tracks available in anodized aluminium or stainless steel finishes
- Suitable for tempered or laminated glass

| Article No. | Finish/Size  | Track |
|-------------|--|-------|
| 51120       | Anodised Aluminium, 2000mm                               |       |
| 51130       | Anodised Aluminium, 3000mm                               |       |
| 51140       | Anodised Aluminium, 4000mm                               |       |
| 51160       | Anodised Aluminium, 6000mm                               |       |
| 51230       | Satin Stainless Steel, 3000mm                            |       |
| 51240       | Satin Stainless Steel, 4000mm                            |       |
| 51260       | Satin Stainless Steel, 6000mm                            |       |
| Article No. | Description  | Image |
| 51172       | Flexiglas fitting set, anodised aluminium, 50kgs         |       |
| 51272       | Flexiglas fitting set, satin stainless steel, 50kgs      |       |
| Article No. | Description  | Image |
| 51181       | Flexiglas 50 standard kit, anodised aluminium, 2000mm    |       |
| 51281       | Flexiglas 50 standard kit, satin stainless steel, 2000mm |       |
| Article No. | Description  | Image |
| 51171       | End caps (set of 2), anodised aluminium                  |       |
| 51271       | End caps (set of 2), satin stainless steel               |       |
| 51191       | Flexiglas 50 opening/soft closing kit, 50kgs             |       |
| 51193       | Synchro kit  |       |
| 51177       | FlexiglasFixedPanel1500mm                                |       |





Flexiglas 120 Glass Door Systems

# Flexiglas 120 Glass Door Systems

## Product Overview

Flexiglas 120 brings a sleek and minimalistic design to any space and offers versatility and transparency to suit customers' aesthetic requirements.

The frameless glass system is suitable for heavier interior glass doors up to 120kg and can also be supplied with soft close cushioning.

### NOTE:

- All accessories to be ordered separately
- For more detailed information please refer to our Technical Data Sheet available on request

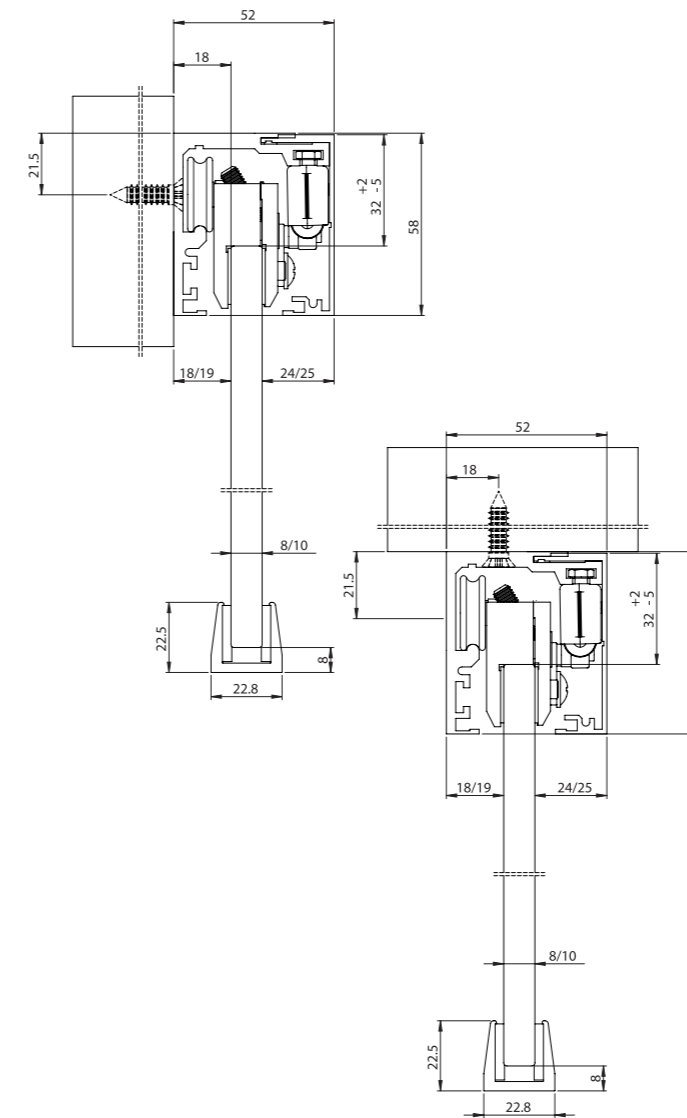

For further information please contact us:  
Tel: +44 (0)20 8545 6680 sales@coburn.co.uk www.coburn.co.uk

| Article No. | Finish/Size   | Track |
|-------------|---|-------|
| 51120       | Anodized Aluminium, 2000mm                                |       |
| 51130       | Anodized Aluminium, 3000mm                                |       |
| 51140       | Anodized Aluminium, 4000mm                                |       |
| 51160       | Anodized Aluminium, 6000mm                                |       |
| 51230       | Satin Stainless Steel, 3000mm                             |       |
| 51240       | Satin Stainless Steel, 4000mm                             |       |
| 51260       | Satin Stainless Steel, 6000mm                             |       |
| Article No. | Description   | Image |
| 51176       | Flexiglas fitting set, anodized aluminium, 120kgs         |       |
| 51276       | Flexiglas fitting set, satin stainless steel, 120kgs      |       |
| Article No. | Description   | Image |
| 51182       | Flexiglas 120 standard kit, anodized aluminium 3000mm     |       |
| 51183       | Flexiglas 120 standard kit, anodized aluminium 4000mm     |       |
| 51282       | Flexiglas 120 standard kit, satin stainless steel, 3000mm |       |
| Article No. | Description   | Image |
| 51171       | End caps (set of 2), anodized aluminium                   |       |
| 51271       | End caps (set of 2), satin stainless steel                |       |
| 51192       | Flexiglas 120 opening/soft closing kit, 80kgs             |       |
| 51193       | Synchro kit   |       |
| 51177       | FlexiglasFixedPanel1500mm                                 |       |

## Door Specifications

- Maximum Door Weight: 120kg
- Glass Thickness: 8mm - 10mm
- Maximum Door Height: 2700mm
- Track Dimensions: 52mm (w) x 58mm (h)

## Hardware Specifications

- No glass preparation required
- Soft opening/closing available as an option
- System is compatible with simultaneous opening kit (Synchro)
- No visible gaps between bottom of track and top of door
- Variable height adjustment on doors
- Additional profiles available for fixed panel mounting
- Tracks available in anodized aluminium or stainless steel finishes
- Suitable for tempered or laminated glass





Vetroslide Glass - Glass Door System

### Door Specification

- Maximum Door Weight: 100kg
- Minimum Door Width: 550mm
- Maximum Door Width: 1000mm
- Door Thickness: 8 - 12mm

### Hardware Specification

- Nylon coated wheels supplied with precision sealed ball bearings
- Anti-jump bar prevents door from being removed from track
- Soft closing as standard, concealed inside the round track
- Choice of hanger styles available on request.

## Vetroslide Glass Glass Door Systems

### Product Overview

Vetroslide Glass sliding hardware offers contemporary look for doors up to 100 kg.

The hardware is manufactured from grade 304 Stainless Steel with a satin brushed finish. The nylon coated bearing wheels ensure the hangers move freely and silently on top of the round bar.

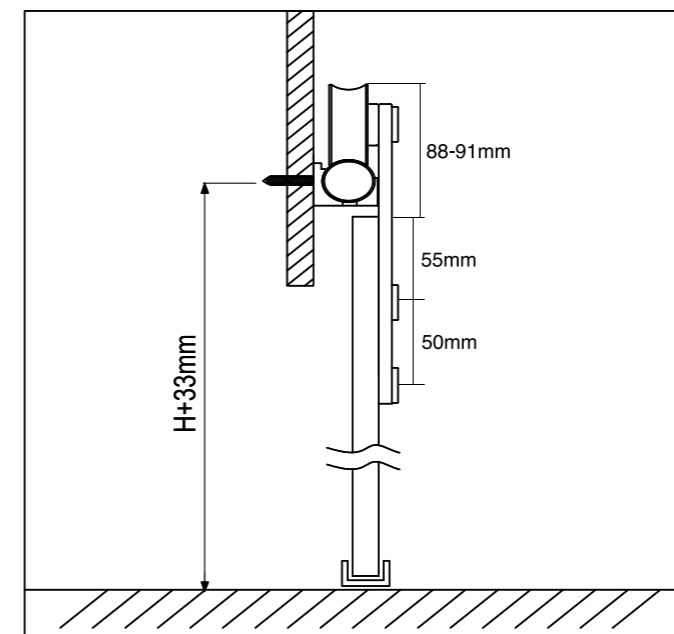
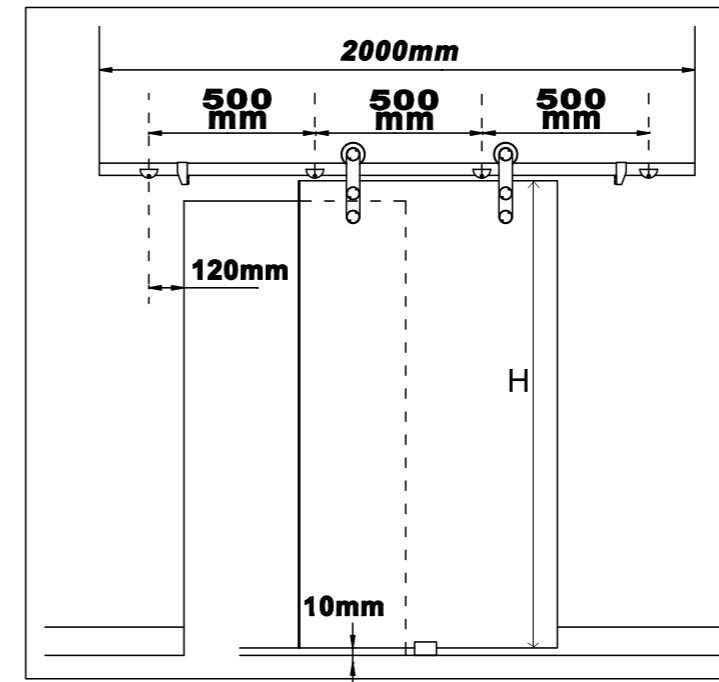

#### NOTE:

- All accessories to be ordered separately
- For more detailed information please refer to our Technical Data Sheet available on request



For further information please contact us:  
Tel: +44 (0)20 8545 6680 sales@coburn.co.uk www.coburn.co.uk



| Article No. | Finish/Size  | Image |
|-------------|--|-------|
| 41271       | Trackset for one Glass Door up to 750 mm Straight Single Wheel Hanger - SS Brush Finish  |       |
| 41272       | Trackset for one Glass Door up to 900 mm Straight Single Wheel Hanger - SS Brush Finish  |       |
| 41273       | Trackset for one Glass Door up to 1000 mm Straight Single Wheel Hanger - SS Brush Finish |       |
| 41274       | Trackset for one Glass Door up to 750 mm Straight Double Wheel Hanger - SS Brush Finish  |       |
| 41275       | Trackset for one Glass Door up to 900 mm Straight Double Wheel Hanger - SS Brush Finish  |       |
| 41276       | Trackset for one Glass Door up to 1000 mm Straight Double Wheel Hanger - SS Brush Finish |       |
| Article No. | Description  | Image |
| 59110       | Crystalline Folding 800mm Pull Handle SS   |       |
| 59111       | Crystalline Folding Round Flush Handle SS  |       |
| 59113       | Crystalline Folding Rectangular Flush Handle SS  |       |



Crystalline Folding EF60 Glass Door Systems

# Crystalline Folding EF60 Glass Door Systems

## Product Overview

Crystalline Folding EF 60 is a stylish system combining function and performance, ideal for maximizing space in structures to create unique openings for entertainment. The frameless glass door system is equipped with unobtrusive and durable components, perfectly suited for end folding glass doors in a variety of residential and commercial applications.

### NOTE:

- All accessories to be ordered separately
- For more detailed information please refer to our Technical Data Sheet available on request

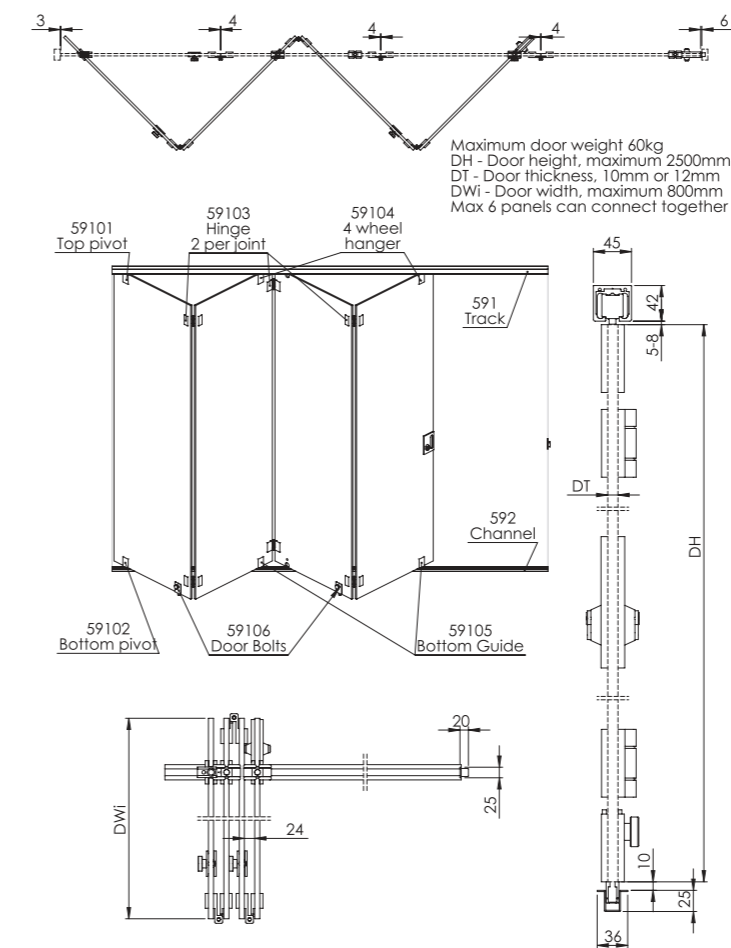

| Article No. | Finish/Size                     | Bottom Channel |
|-------------|---------------------------------|----------------|
| 59220       | Stainless steel Channel, 2000mm |                |
| 59230       | Stainless steel Channel, 3000mm |                |
| 59240       | Stainless steel Channel, 4000mm |                |
| 59250       | Stainless steel Channel, 5000mm |                |



For further information please contact us:  
Tel: +44 (0)20 8545 6680 sales@coburn.co.uk www.coburn.co.uk

| Article No. | Finish/Size                                     | Track |
|-------------|---|-------|
| 59120       | Anodised Aluminium, 2000mm                      |       |
| 59130       | Anodised Aluminium, 3000mm                      |       |
| 59140       | Anodised Aluminium, 4000mm                      |       |
| 59150       | Anodised Aluminium, 5000mm                      |       |
| Article No. | Description                                     | Image |
| 59101       | Crystalline Folding Top Pivot                   |       |
| 59102       | Crystalline Folding Bottom Pivot                |       |
| 59103       | Crystalline Folding Hinge                       |       |
| 59104       | Crystalline Folding Hanger c/w Clamp            |       |
| 59105       | Crystalline Folding Bottom Guide c/w Clamp      |       |
| 59106       | Crystalline Folding Bottom Bolt                 |       |
| 59109       | Crystalline Folding Floor Lock                  |       |
| 59110       | Crystalline Folding 800mm Pull Handle SS        |       |
| 59111       | Crystalline Folding Round Flush Handle SS       |       |
| 59113       | Crystalline Folding Rectangular Flush Handle SS |       |
| 59115       | Crystalline Folding Lock Glass to Wall SS       |       |
| 59116       | Crystalline Folding Lock Glass to Glass SS      |       |
| 59117       | Crystalline Folding Hinge Glass to wall         |       |



### Door Specifications

- Maximum Door Weight: 60kg
- Maximum Door Height: 2500mm
- Maximum Door Width: 800mm
- Glass Thickness: 10mm - 12mm
- Track Dimensions: 45mm (w) x 42mm (h)

### Hardware Specifications

- Vertical height adjustment
- Smooth and silent operation
- Suitable for up to 6 leaves
- Minimal space required in stacking area
- Manufactured from Grade 304 Stainless Steel





Crystalline Folding CF60 Glass Door Systems

# Crystalline Folding CF60 Glass Door Systems

## Product Overview

Crystalline Folding CF 60 is a stylish system combining function with performance, giving an uninterrupted view. It is ideal for maximising the flow of light between spaces. This frameless glass folding door system is equipped with unobtrusive and durable components which gives the system both smooth running operation and elegant design with clean lines. The option to have access doors separate to or as part of the folding suite gives flexibility of layout for convenient use and the use of door bolts to hold the leaves flush when closed eliminates the need for a floor channel giving a clear boundary free threshold making this system suited for centre folding glass doors in a variety of residential and commercial applications.

### NOTE:

- All accessories to be ordered separately
- For more detailed information please refer to our Technical Data Sheet available on request

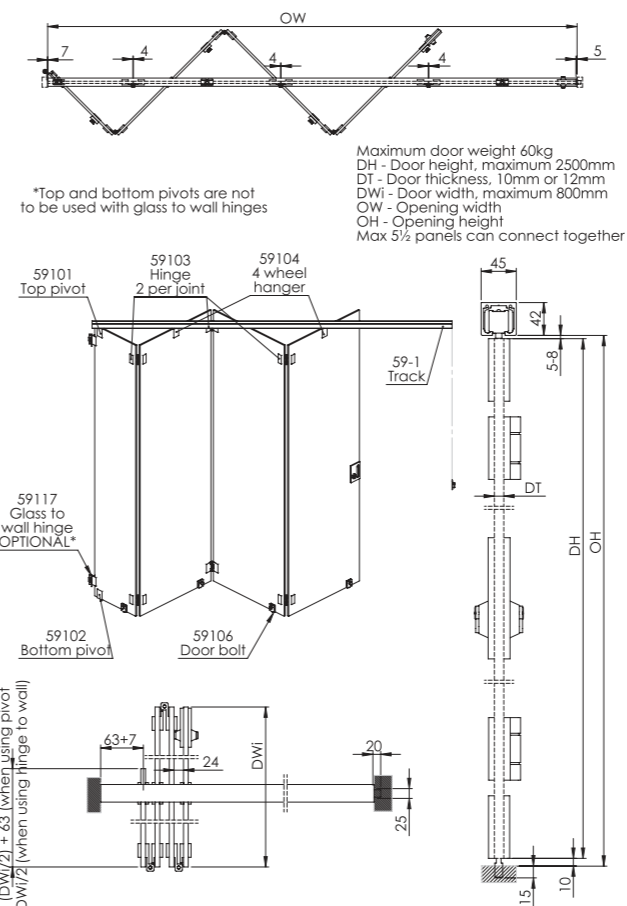

## Door Specifications

- Maximum Door Weight: 60kg
- Maximum Door Height: 2500mm
- Maximum Door Width: 800mm
- Glass Thickness: 10mm - 12mm
- Track Dimensions: 45mm (w) x 42mm (h)

## Hardware Specifications

- Vertical height adjustment
- Smooth and silent operation
- Max. 5½ panels can connect together
- Locking available if required
- Minimal space required in stacking area
- Manufactured from Grade 304 Stainless Steel
- No recessed floor channel required giving a clear threshold



For further information please contact us:  
Tel: +44 (0)20 8545 6680 sales@coburn.co.uk www.coburn.co.uk

| Article No. | Finish/Size   | Track |
|-------------|---|-------|
| 59120       | Anodised Aluminium, 2000mm                          |       |
| 59130       | Anodised Aluminium, 3000mm                          |       |
| 59140       | Anodised Aluminium, 4000mm                          |       |
| 59150       | Anodised Aluminium, 5000mm                          |       |
| Article No. | Description   | Image |
| 59101       | Crystalline Folding Top Pivot                       |       |
| 59102       | Crystalline Folding Bottom Pivot                    |       |
| 59103       | Crystalline Folding Hinge                           |       |
| 59104       | Crystalline Folding Hanger c/w Clamp                |       |
| 59107       | Crystalline Folding Bottom Bolt                     |       |
| 59108       | Crystalline Folding CF60 Keep for 59107 Bottom Bolt |       |
| 59109       | Crystalline Folding Floor Lock                      |       |
| 59110       | Crystalline Folding 800mm Pull Handle SS            |       |
| 59111       | Crystalline Folding Round Flush Handle SS           |       |
| 59113       | Crystalline Folding Rectangular Flush Handle SS     |       |
| 59115       | Crystalline Folding Lock Glass to Wall SS           |       |
| 59116       | Crystalline Folding Lock Glass to Glass SS          |       |
| 59117       | Crystalline Folding Hinge Glass to wall             |       |



Ideal for residential or commercial applications, these sliding door systems allow wardrobe doors to silently glide with effortless ease.

# Wardrobe Sliding Door Systems







# Flushslide

## Wardrobe Sliding Door Systems

### Product Overview

Flushslide is a stylish and contemporary hardware system combining smooth and silent operation, enabling flush fitted sliding wardrobe doors to open by co-planing across the face of the other wardrobe doors.

With all components discreetly concealed behind the wardrobe doors and equipped with soft closing dampeners this versatile system offers countless interior design possibilities.

#### NOTE:

- All accessories to be ordered separately
- For more detailed information please refer to our Technical Data Sheet available on request

| Article No. | Description  | Image |
|-------------|--|-------|
| 83120       | Flushslide top & bottom rail, natural anodized aluminium, 2000mm |       |
| 83130       | Flushslide top & bottom rail, natural anodized aluminium, 3000mm |       |
| 83140       | Flushslide top & bottom rail, natural anodized aluminium, 4000mm |       |
| 83222       | Flushslide sliding unit, left hand, 85kgs                        |       |
| 83224       | Flushslide sliding unit, left hand, 55kgs                        |       |
| 83223       | Flushslide sliding unit, right hand, 85kgs                       |       |
| 83225       | Flushslide sliding unit, right hand, 55kgs                       |       |
| 83226       | Flushslide sliding unit, centre (3 door), 55kgs                  |       |

### Flushslide Wardrobe Sliding Door Systems

#### Door Specifications

- Maximum Door Weight: 85kg
- Door Thickness: 20-45mm
- Maximum Door Height: 3000mm

#### Hardware Specifications

- Sliding doors aligned in a single plane when doors are in closed position (no overlapping)
- Top and bottom tracks are supplied in anodized aluminium finish
- Tracks and sliding mechanisms are concealed when doors are in open or closed positions
- System supplied with integrated soft closing and soft opening dampeners as standard
- Suitable for large wardrobe sliding doors
- Tracks can be easily cut to size
- Kits available for 2 or 3 sliding doors.

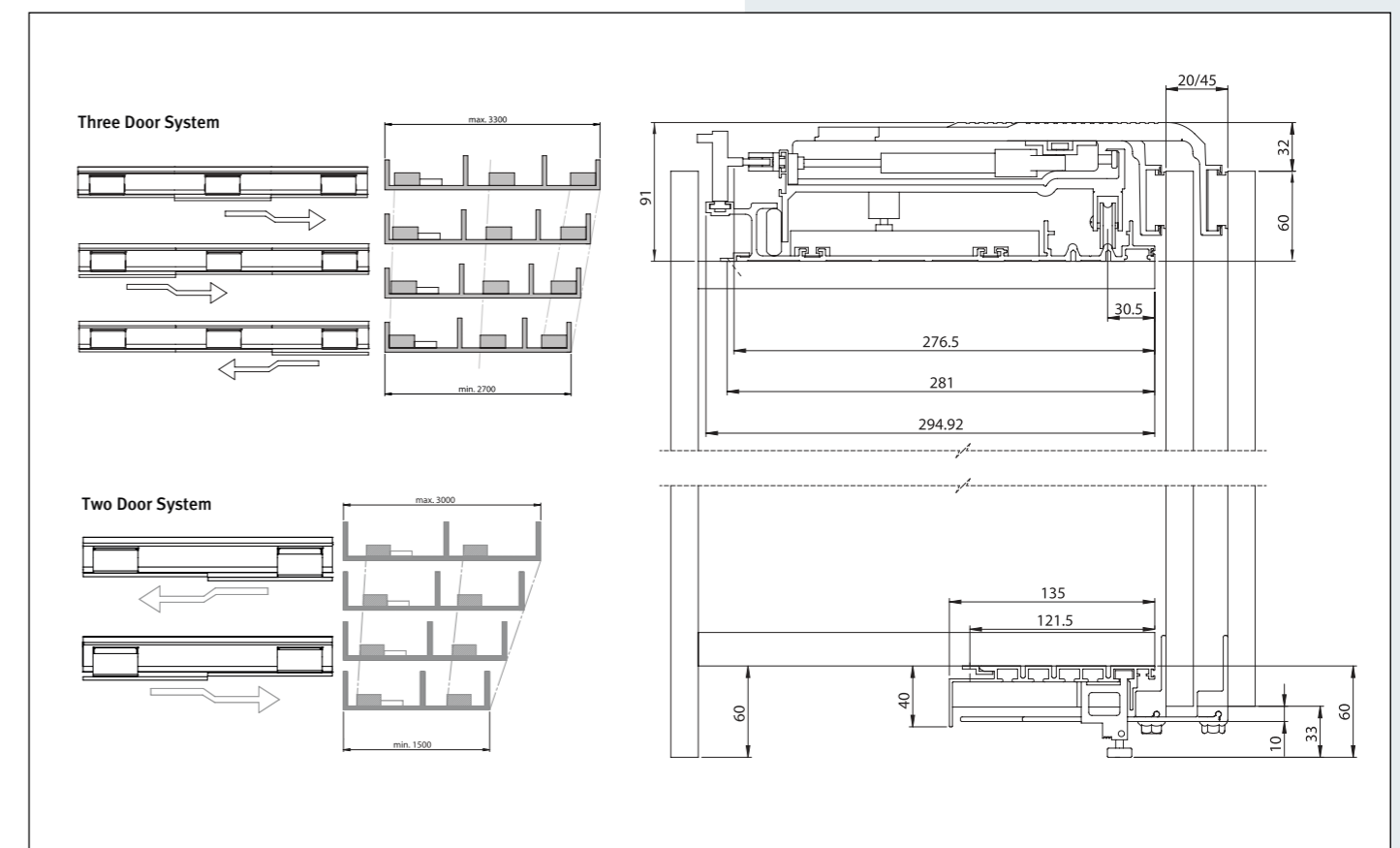



Slyde 15 Timber - Wardrobe Sliding Door System

### Door Specification

- Maximum weight for a single door: 15kg
- Wooden door thickness: 16-19mm
- Single door size width: 500-1200mm

### Hardware Specification

- Nylon wheels for silent performance and durability.
- Integrated soft closing and opening as standard.

# Slyde 15 Timber

## Wardrobe Sliding Door Systems

### Product Overview

Slyde 15 system provides a highly functional solution for bookcases, display units and cabinet doors. Equipped with single or double concealed top tracks that can be accurately cut to the desired length, which ensures a professional and streamlined appearance. This systems also offers component packs for both timber and glass doors, which include soft close dampers as standard, ensuring a smooth and quiet door closure everytime. Slyde 15 is a versatile and straight forward option for sliding cabinet doors that requires minimal installation effort.

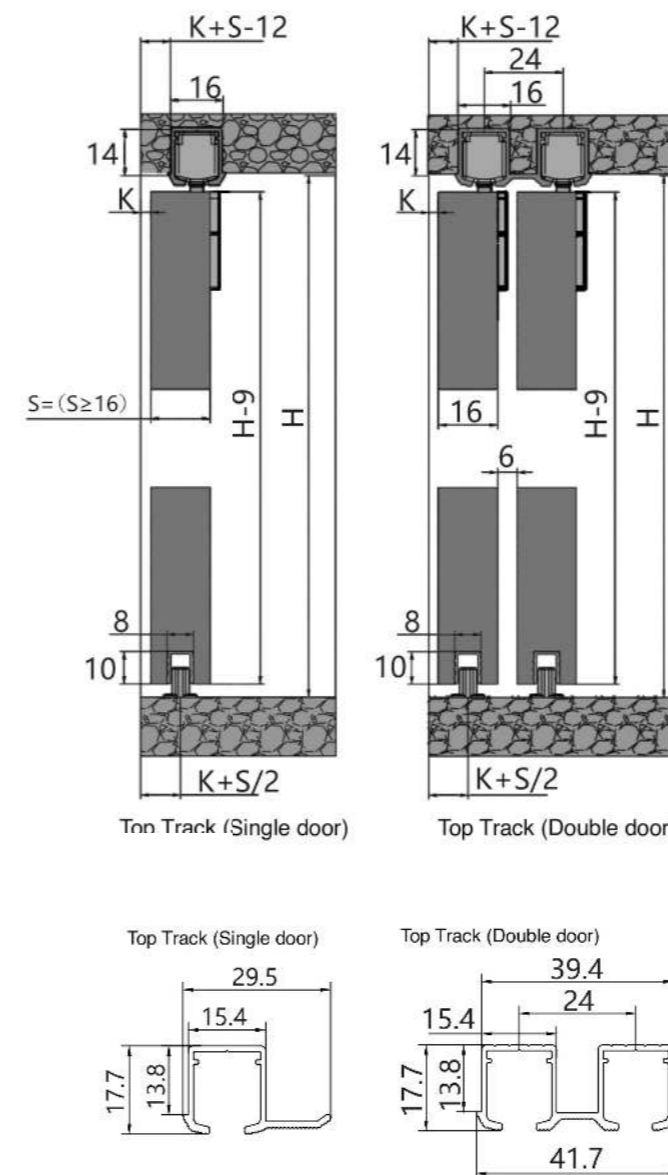

### NOTE:

- All accessories to be ordered separately
- For more detailed information please refer to our Technical Data Sheet available on request



Wardrobe Sliding Door Systems



For further information please contact us:

Tel: +44 (0)20 8545 6680 sales@coburn.co.uk www.coburn.co.uk

| Article No. | Finish/Size  | Single Track                 |
|-------------|--|------------------------------|
| 81110       | Slyde 15 (1m) Single Track for Timber & Glass, Silver anodised |                              |
| 81120       | Slyde 15 (2m) Single Track for Timber & Glass, Silver anodised |                              |
| 81130       | Slyde 15 (3m) Single Track for Timber & Glass, Silver anodised |                              |
| Article No. | Finish/Size  | Double Timber Set Track      |
| 81210       | Slyde 15 (1m) Double Track for Timber, Silver anodised         |                              |
| 81220       | Slyde 15 (2m) Double Track for Timber, Silver anodised         |                              |
| 81230       | Slyde 15 (3m) Double Track for Timber, Silver anodised         |                              |
| Article No. | Finish/Size  | Bottom Channel               |
| 81310       | Slyde 15 (1m) Bottom Channel for Timber, Silver anodised       |                              |
| 81320       | Slyde 15 (2m) Bottom Channel for Timber, Silver anodised       |                              |
| 81330       | Slyde 15 (3m) Bottom Channel for Timber, Silver anodised       |                              |
| Article No. | Finish/Size  | 1 Door Components Set Timber |
| 81101       | Slyde 15 1 Door Component Set (Timber)                         |                              |
| Article No. | Description  | Image                        |
| 95612       | Rectangular Flush Handle-Stainless Steel Finish 100x50x19mm    |                              |
| 95680       | Round Flush Pull - Satin Silver Finish 58x11mm                 |                              |
| 95681       | Round Flush Pull - Polished Brass Finish 58x11mm               |                              |
| 95683       | Round Flush Pull - Stainless steel SS Brush finish 65x14mm     |                              |





Slyde 50 - Wardrobe Sliding Door Systems

### Door Specification

- Maximum Door Weight: 50kg
- Door Thickness: 14 - 45mm
- Maximum Door Height: 2700mm

### Hardware Specification

- Kits available for 2 and 3 sliding doors with exterior door overlapping
- Equipped with soft open and close dampers as standard
- Concealed top and bottom aluminium tracks

# Slyde 50

## Wardrobe Sliding Door Systems

### Product Overview

Slyde 50 is a space saving solution for sliding wardrobe and cupboard doors. Its innovative design features concealed top and bottom tracks that can be easily trimmed to fit the desired length, ensuring a seamless and elegant look. The system comes equipped with soft closing dampers, ensuring a smooth and quiet closure everytime. Suitable for a wide range of door thicknesses.

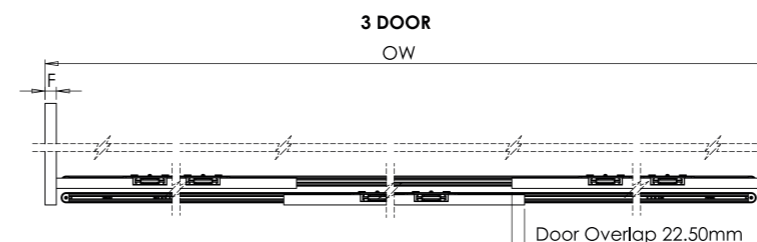
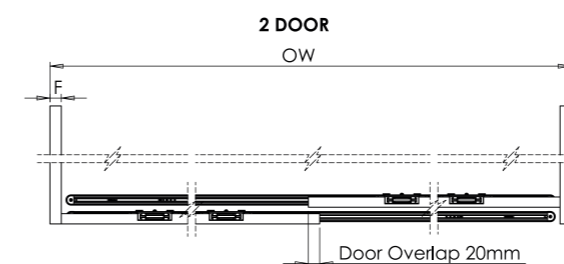
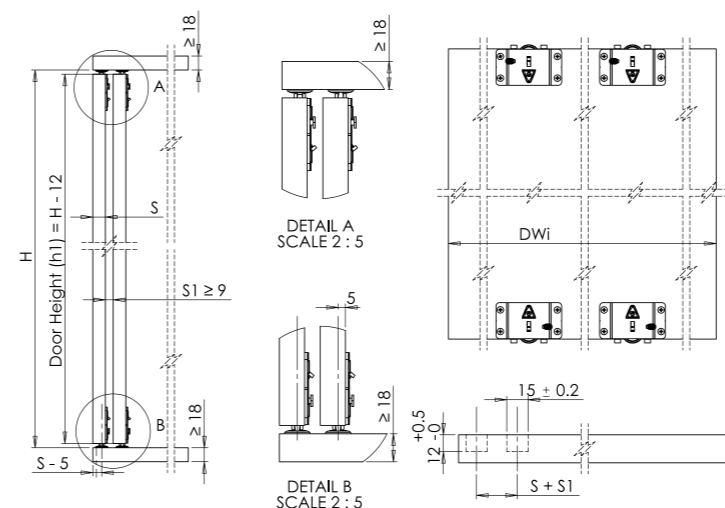

#### NOTE:

- All accessories to be ordered separately
- For more detailed information please refer to our Technical Data Sheet available on request



Wardrobe Sliding Door Systems

For further information please contact us:

Tel: +44 (0)20 8545 6680 sales@coburn.co.uk www.coburn.co.uk

| Article No. | Finish/Size   | Track            |
|-------------|---|------------------|
| 86620       | Slyde 50 (2.0m) top and bottom track, silver anodised                 |                  |
| 86630       | Slyde 50 (3.0m) top and bottom track, silver anodised                 |                  |
| Article No. | Finish/Size   | 2 Door Component |
| 86701       | Slyde 50 2 door components pack                                       |                  |
| Article No. | Finish/Size   | 3 Door Component |
| 86702       | Slyde 50 3 door components pack                                       |                  |
| Article No. | Description   | Image            |
| 95612       | Rectangular Flush Handle-Stainless Steel Finish 100x50x19mm           |                  |
| 95625       | Stainless Steel round handle Diameter 90mm                            |                  |
| 95626       | Stainless Steel round handle with concealed screw holes Diameter 90mm |                  |
| 95628       | Stainless Steel handle with concealed screw holes 180 x 45mm          |                  |
| 95629       | Stainless Steel handle with concealed screw holes 180 x 60mm          |                  |
| 95680       | Round Flush Pull - Satin Silver Finish 58x11mm                        |                  |
| 95681       | Round Flush Pull - Polished Brass Finish 58x11mm                      |                  |
| 95683       | Round Flush Pull - Stainless steel SS Brush finish 65x14mm            |                  |
| 95630       | Rectangular Flush Pull Handle 180x45mm - Black Finish                 |                  |



Celantur 50 Wardrobe Sliding Door Systems

### Door Specifications

- Maximum Door Weight: 50kg
- Door Thickness: 14-20mm
- Maximum Door Height: 2700mm

### Hardware Specifications

- Slim top and bottom aluminium tracks, supplied with bottom track cover
- Equipped with soft closing dampers as standard
- Soft closing dampers concealed in the track
- Variable door height adjustment
- Kits available for 2 and 3 sliding doors

## Celantur 50 Wardrobe Sliding Door Systems

### Product Overview

Celantur 50 is a neat and stylish wardrobe sliding system that uses upper and lower tracks combined with smooth running rollers that enable the doors to glide effortlessly in a single plane.

The system is very easy to install as all the parts are face fixed on the back face of the door and no routing or machining is required. Centaur 50 is supplied with soft closing dampers as standard, and is perfectly suited for light to medium weight wardrobe doors.

#### NOTE:

- All accessories to be ordered separately
- For more detailed information please refer to our Technical Data Sheet available on request

| Article No. | Description                                   | Image |
|-------------|---|-------|
| 86820       | Celantur 50 (2m) top & bottom track, anodised |       |
| 86830       | Celantur 50 (3m) top & bottom track, anodised |       |
| 86901       | Celantur 50 2 door components pack            |       |
| 86902       | Celantur 50 3 door components pack            |       |

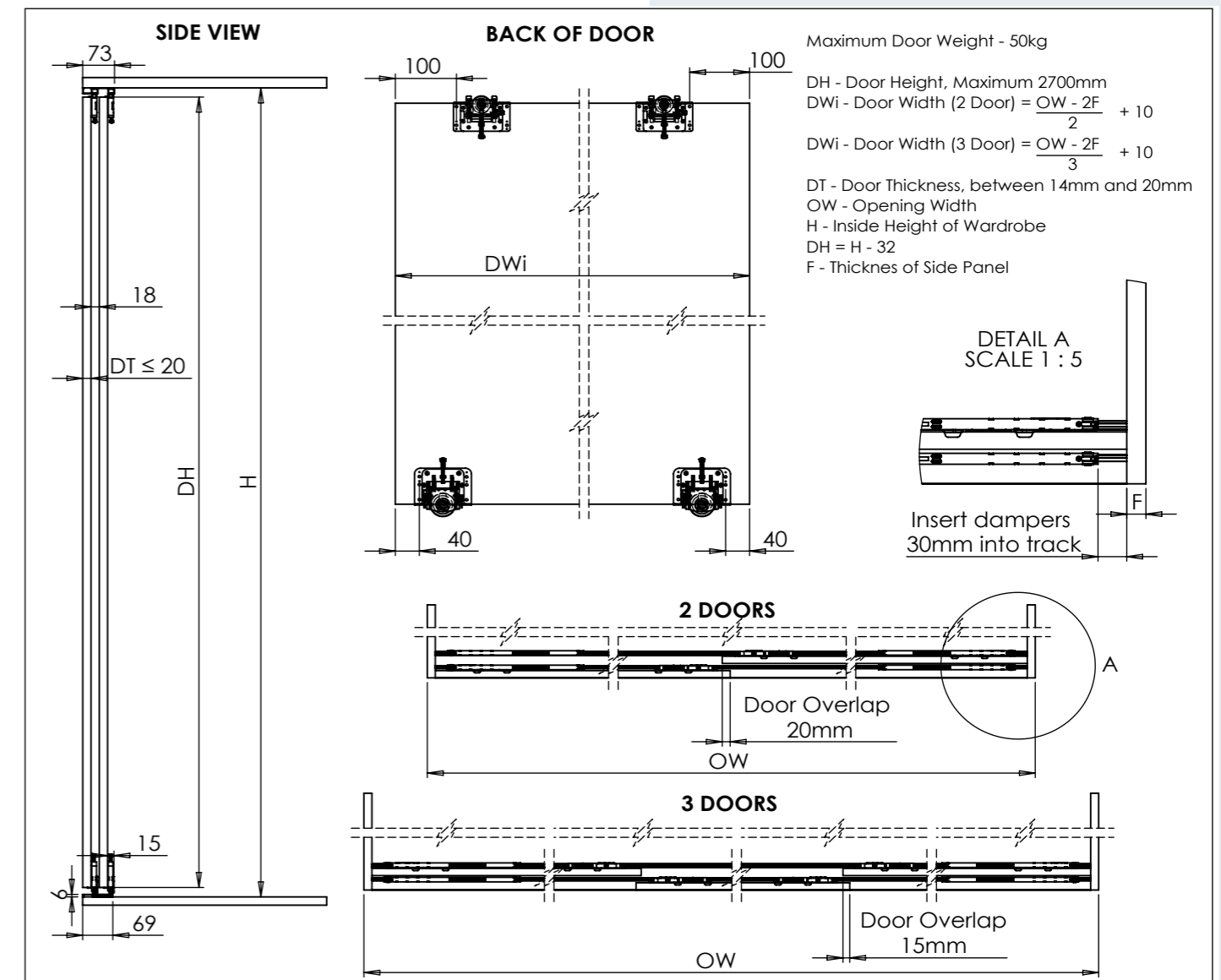





Topslide 50 - Wardrobe Sliding Door System

# Topslide 50

## Wardrobe Sliding Door Systems

### Product Overview

Topslide 50 is a neat and stylish wardrobe sliding system that uses upper and lower tracks combined with smooth running rollers that enable the door to glide effortlessly in a single plane. The system is perfectly suited for light to medium weight wardrobe doors.

Calculation of cabinet size  $K1=K+36$  (T=Thickness of door  $18 \leq T \leq 25$ )  
Width of door depends on the actual shape of door

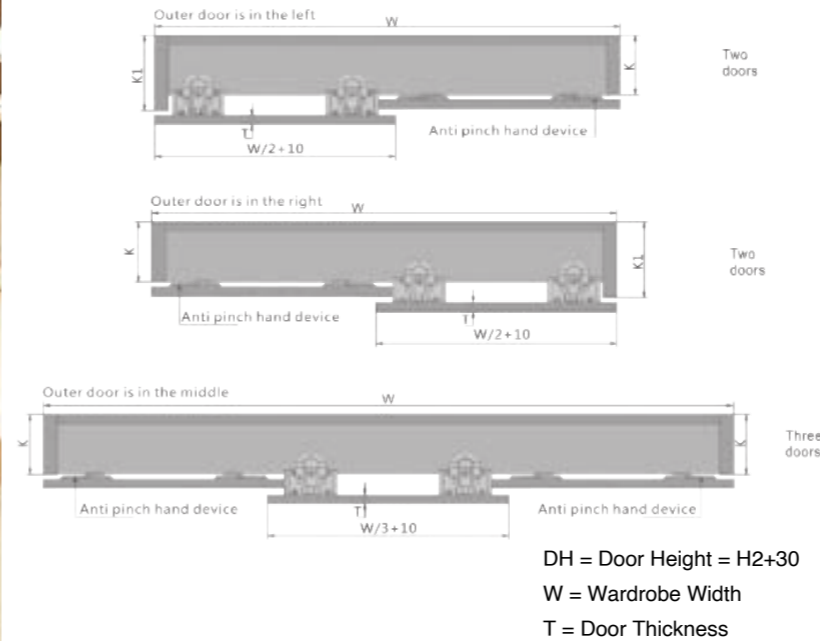

### SIDE VIEW

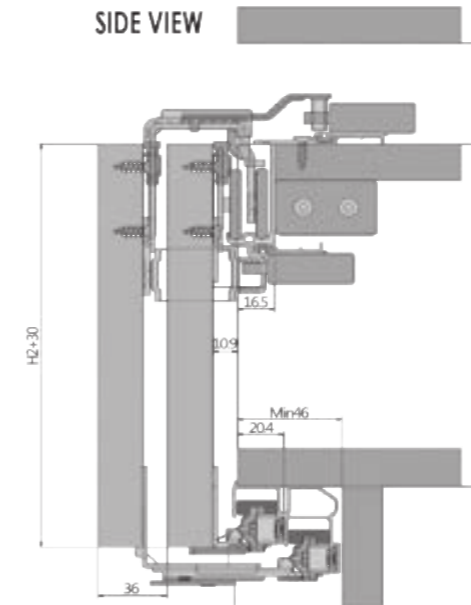

### NOTE:

- All accessories to be ordered separately
- For more detailed information please refer to our Technical Data Sheet available on request

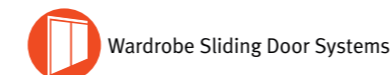

For further information please contact us:  
Tel: +44 (0)20 8545 6680 sales@coburn.co.uk www.coburn.co.uk

| Article No. | Finish/Size   | Tracks               |
|-------------|---|----------------------|
| 88520       | Topslide (2m) Top and Bottom Track, Silver anodised                   |                      |
| 88530       | Topslide (3m) Top and Bottom Track, Silver anodised                   |                      |
| 88540       | Topslide (4m) Top and Bottom Track, Silver anodised                   |                      |
| Article No. | Finish/Size   | 2 Door Component Set |
| 88601       | Topslide 50, 2 Door Component Set                                     |                      |
| Article No. | Finish/Size   | 3 Door Component Set |
| 88602       | Topslide 50, 3 Door Component Set                                     |                      |
| Article No. | Description   | Image                |
| 95612       | Rectangular Flush Handle-Stainless Steel Finish 100x50x19mm           |                      |
| 95625       | Stainless Steel round handle Diameter 90mm                            |                      |
| 95626       | Stainless Steel round handle with concealed screw holes Diameter 90mm |                      |
| 95628       | Stainless Steel handle with concealed screw holes 180 x 45mm          |                      |
| 95629       | Stainless Steel handle with concealed screw holes 180 x 60mm          |                      |
| 95680       | Round Flush Pull - Satin Silver Finish 58x11mm                        |                      |
| 95681       | Round Flush Pull - Polished Brass Finish 58x11mm                      |                      |
| 95683       | Round Flush Pull - Stainless steel SS Brush finish 65x14mm            |                      |
| 95630       | Rectangular Flush Pull Handle 180x45mm - Black Finish                 |                      |



Celantur 80 Wardrobe Sliding Door Systems

### Door Specifications

- Maximum Door Weight: 80kg
- Door Thickness: 16-46mm
- Maximum Door Height: 3000mm

### Hardware Specifications

- Supplied with upper and lower aluminium rails, which when fitted are concealed at the back of the sliding doors
- Equipped with soft closing dampers as standard
- Built in anti-jump mechanism comes as standard
- Variable thickness adjustment
- Kits available for 2 or 3 sliding doors with exterior door overlapping
- Self cleaning rollers

# Celantur 80

## Wardrobe Sliding Door Systems

### Product Overview

Celantur 80 is a desirable and elegant wardrobe sliding system using a combination of upper and lower rails, neatly concealed at the rear of the doors, which enables the doors to glide effortlessly in a single plane. The system which is supplied with soft closing and soft opening dampers for all doors as standard, is perfectly suited for larger sized wardrobe doors.

#### NOTE:

- All accessories to be ordered separately
- For more detailed information please refer to our Technical Data Sheet available on request

| Article No. | Description                                   | Image |
|-------------|---|-------|
| 88130       | Celantur 80 (3m) top & bottom track, anodised |       |
| 88140       | Celantur 80 (4m) top & bottom track, anodised |       |
| 88201       | Celantur 80 2 door components pack            |       |
| 88202       | Celantur 80 3 door components pack            |       |

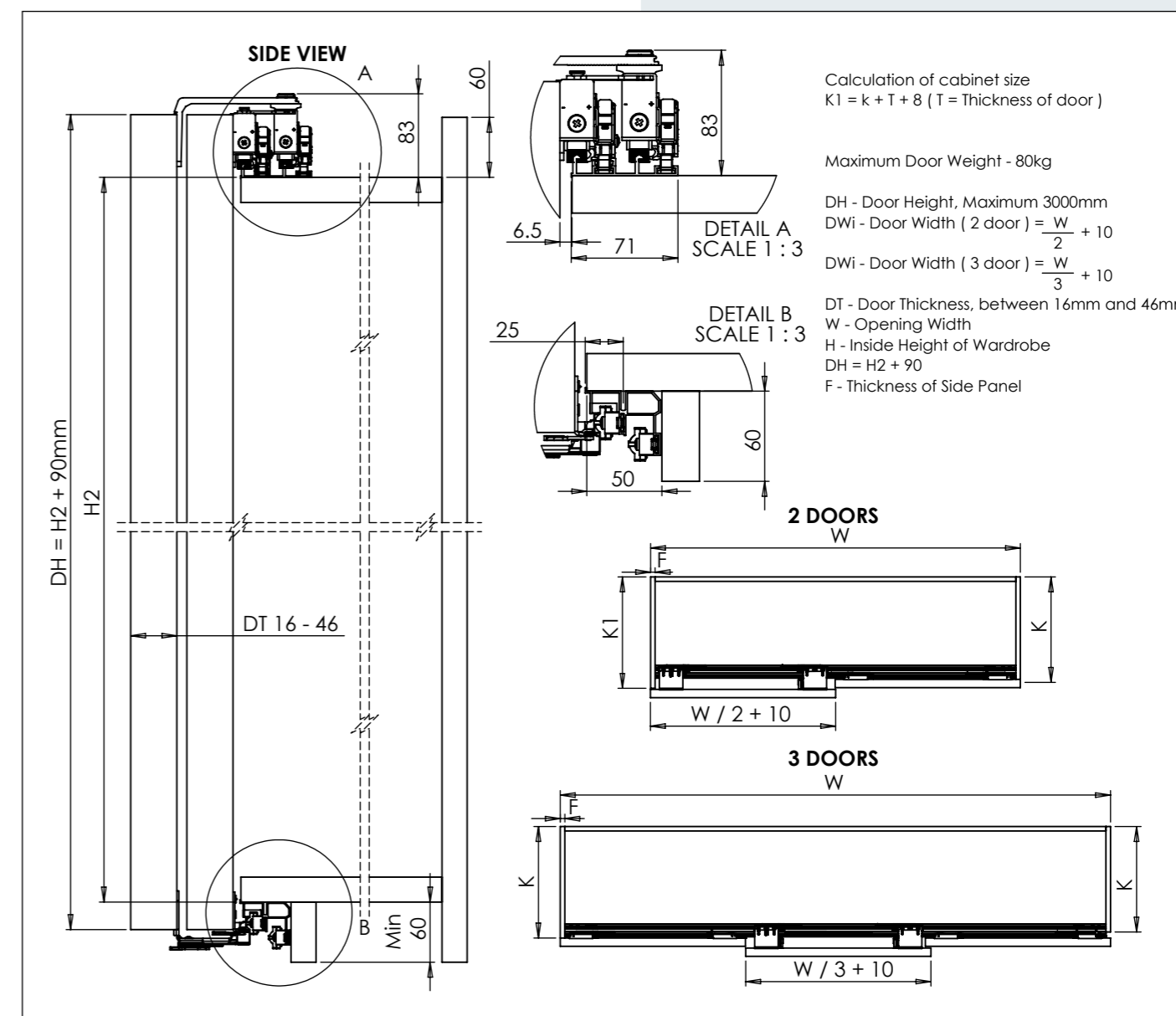





# Celantur Folding Wardrobe

## Wardrobe Sliding Door Systems

### Product Overview

The Celantur Folding wardrobe is a stylish wardrobe system combining function with performance. It is equipped with unobtrusive and durable components which give the system a smooth running operation and elegant design with clean lines. The system is perfectly suited for light weight wardrobe doors.

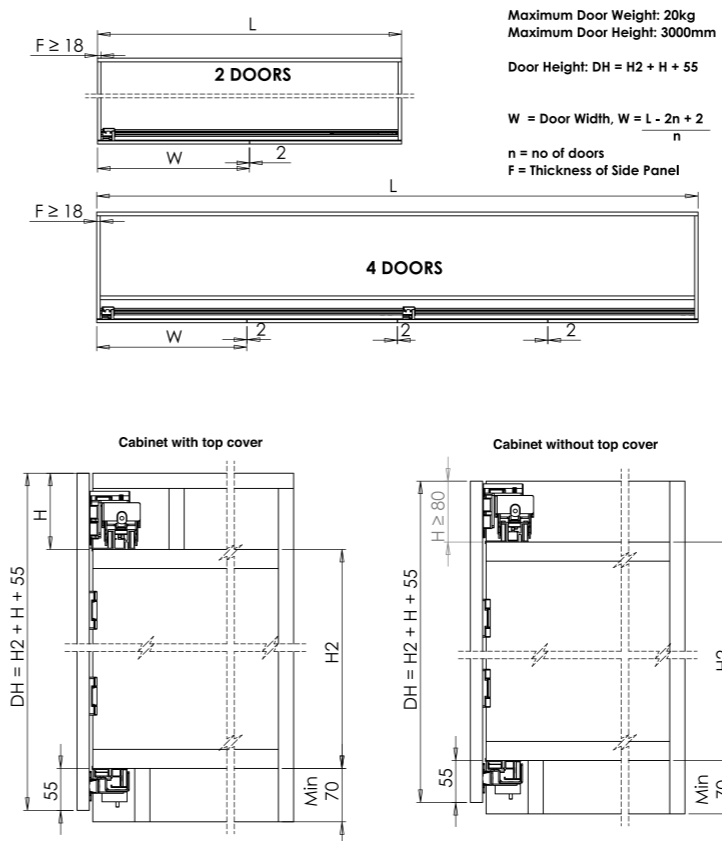

### Celantur Folding - Wardrobe Sliding Door Systems

#### Door Specification

- Maximum Door Weight: 20kg
- Door Thickness:  $\geq 16\text{mm}$
- Maximum Door Height: 3000mm

#### Hardware Specification

- Supplied with upper and lower aluminium rails, which when fitted are concealed behind the sliding doors.
- Equipped with soft closing dampers as standard.
- Soft closing dampers concealed in the track.
- Variable door height adjustment.

#### NOTE:

- All accessories to be ordered separately
- For more detailed information please refer to our Technical Data Sheet available on request

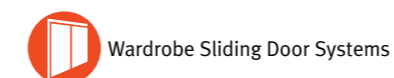

For further information please contact us:  
Tel: +44 (0)20 8545 6680 sales@coburn.co.uk www.coburn.co.uk



| Article No. | Finish/Size   | Track            |
|-------------|---|------------------|
| 89624       | Celantur Folding (2.4m) top and bottom track, silver anodised         |                  |
| 89636       | Celantur Folding (3.6m) top and bottom track, silver anodised         |                  |
| Article No. | Finish/Size   | 2 Door Component |
| 89701       | Celantur Folding 2 door components pack                               |                  |
| Article No. | Description   | Image            |
| 85612       | Rectangular Flush Handle-Stainless Steel Finish 100x50x19mm           |                  |
| 95625       | Stainless Steel round handle Diameter 90mm                            |                  |
| 95626       | Stainless Steel round handle with concealed screw holes Diameter 90mm |                  |
| 95628       | Stainless Steel handle with concealed screw holes 180 x 45mm          |                  |
| 95629       | Stainless Steel handle with concealed screw holes 180 x 60mm          |                  |
| 95630       | Rectangular Flush Pull Handle Black Finish - 180x45mm                 |                  |
| 95680       | Round Flush Pull - Satin Silver Finish 58x11mm                        |                  |
| 95681       | Round Flush Pull - Polished Brass Finish 58x11mm                      |                  |
| 95683       | Round Flush Pull - Stainless steel SS Brush finish 65x14mm            |                  |